

## **IMPORTANT SAFETY INSTRUCTIONS**

**WARNING** – When using electric products, basic precautions should always be followed, including the following:

- 1) Read all the instructions before using the product.
- 2) Do not use this product near water – for example, near a bathtub, washbowl, kitchen sink, in a wet basement, or near a swimming pool or the like.
- 3) This product should be used only with a cart or stand that is recommended by the manufacturer.
- 4) This product, in combination with an amplifier and headphones or speakers, may be capable of producing sound levels that could cause permanent hearing loss. Do not operate for a long period of time at a high volume level or at a level that is uncomfortable. If you experience any hearing loss or ringing in your ears, you should consult an audiologist.
- 5) The product should be located so that its location does not interfere with its proper ventilation.
- 6) The product should be located away from heat sources such as radiators, heat registers, or other products that produce heat.
- 7) The product should be connected to a power supply only of the type described in the operating instructions or as marked on the product.
- 8) The power-supply cord of the product should be unplugged from the outlet when left unused for a long period of time.
- 9) Care should be taken so that objects do not fall and liquids are not spilled into the enclosure through openings.
- 10) The product should be serviced by qualified personnel when:
  - a) The power-supply cord or the plug has been damaged; or
  - b) Objects have fallen, or liquid has been spilled onto the product; or
  - c) The product has been exposed to rain; or
  - d) The product does not appear to operate normally or exhibits a marked change in performance; or
  - e) The product has been dropped or the enclosure damaged.
- 11) Do not attempt to service the product beyond that described in the user-maintenance instructions. All other servicing should be referred to qualified service personnel.

**DANGER:** INSTRUCTIONS PERTAINING TO RISK OF FIRE, ELECTRIC SHOCK, OR INJURY TO PERSONS: Do not open the chassis. There are no user serviceable parts inside. Refer all servicing to qualified personnel only.

### GROUNDING INSTRUCTIONS:

This product must be grounded. If it should malfunction or breakdown, grounding provides a path of least resistance for electrical current to reduce the risk of electric shock. This product is equipped with a cord having an equipment grounding connector and a grounding plug. The plug must be plugged into an appropriate outlet that is properly installed and grounded in accordance with all local codes and ordinances.

**DANGER** – Improper connection of the equipment-grounding connector can result in a risk of electric shock. Check with a qualified electrician or serviceman if you are in doubt as to whether the product is properly grounded. Do not modify the plug provided with this product – if it will not fit in the outlet, have a proper outlet installed by a qualified electrician.

# SAVE THESE INSTRUCTIONS

USER's MANUAL for the

minimoog®



By R. Stephen Dunnington

**Here it is** – the minimoog Voyager®. Moog Music has put more than 30 years of experience with analog synthesizer technology into the design of this instrument to bring you the fattest lead synthesizer since the minimoog was introduced in 1970. We've done away with the things that made 30-year-old analog synthesizers difficult – the tuning instability, the lack of patch memory, and the lack of compatibility with MIDI gear. We've kept the good parts – the rugged construction, the fun of changing a sound with knobs in real time, and the amazing, warm, fat, pleasing analog sound. The Voyager is our invitation to you to explore analog synthesis and express yourself. It doesn't matter what style of music you play – the Voyager is here to help you tear it up in the studio, on stage, or in the privacy of your own home. Have fun!

**Acknowledgements** – Thanks to Bob Moog for designing yet another fantastic music making machine! Thanks are also due to the Moog Music Team, Rudi Linhard of Lintronics for his amazing software, Brian Kehew, Zon Vern Pyles, all the great folks who contributed design ideas, and of course, you – the Moog Music customer.

## TABLE OF CONTENTS:

I. Getting Started.....	3
II. The Basics of Analog Synthesis.....	6
III. The Voyager's features.....	13
IV. The Voyager's Components	
A. Mixer.....	17
B. Oscillators.....	19
C. Filters.....	22
D. Envelope Generators.....	26
E. Audio Outputs.....	29
F. Mod Busses.....	30
G. LFO/ Sample and Hold.....	33
H. Keyboard and Left Hand Control Panel .....	35
I. The Touch Surface Controller .....	36
J. The Back Panel .....	37
K. The User Interface/Voyager Software version 2.5.....	38
1. The Interface.....	38
2. Master Mode.....	39
3. Edit Mode.....	42
4. Panel Mode.....	49
5. MIDI.....	51
Appendix A: Caring for your Voyager.....	54
Appendix B: Service and Technical Support Information.....	54
Appendix C: List of Presets.....	55
Appendix D: MIDI Implementation Chart.....	58
Appendix E: VX-351 User's Guide.....	59

Note: Specifications subject to change without notice.  
© Moog Music Inc. 2002, 2003 All rights reserved.



## I. Getting Started

For those of you who can't wait to read the manual (perfectly understandable when you have a brand new synthesizer...), the following are the important steps to get you going with your new Voyager. Once the adrenaline subsides a bit, you will find this manual to be an excellent guide to exploring the outer reaches of your minimoog Voyager.

### - *Check the contents in the shipping carton*

The Voyager comes in a carton with a removable lid, and contains the following: The minimoog Voyager itself, a power cord, and the bag that contains the manual and warranty registration card.

### - *What you will need*

In addition to the Voyager and its provided accessories, you will need:

- A keyboard stand or table that will hold the Voyager,
- (1) 1/4" instrument cable for connecting in mono, or (2) 1/4" instrument cables for connecting in stereo,
- an amplifier, or headphones,
- a properly wired AC outlet.

### - *Warranty registration*

Before you get started with your Voyager, please fill out your warranty registration card and send it to Moog Music Inc. This will activate your warranty and is a vital piece of information for us to provide you with the best service.

### - *Remove the Voyager from the carton*

Before you remove the Voyager from the carton, make sure you have a space in mind to set it up. Keep in mind that you will need a keyboard stand or table that will support a 40 lb. analog synthesizer and will not topple if you play hard. The Voyager weighs about 40 lbs., so use caution when lifting it out of the carton. Make sure to save the packaging in case you need to ship the Voyager for any reason.

### - *Set tilt of panel*

The Voyager's front panel can be tilted for comfortable adjustment of the panel controls while you play the keyboard. Once the Voyager is on a stand, the Voyager's panel can be lifted by the handle on the back of the instrument and set to one of 5 angles. Pull the front panel forward and lift the hinged support for the panel and insert the tab into the appropriate slot on the back panel for your desired front panel angle. *CAUTION: Do not over-tilt the front panel when pulling it forward.* Make sure the support bracket is properly seated into the slots on the back panel before playing.

### - *Connect to source of AC*

Connect the Voyager's power receptacle to a wall outlet with the supplied AC cordset (see figure 1). The Voyager will operate with a power source from 100 to 240 Volts.

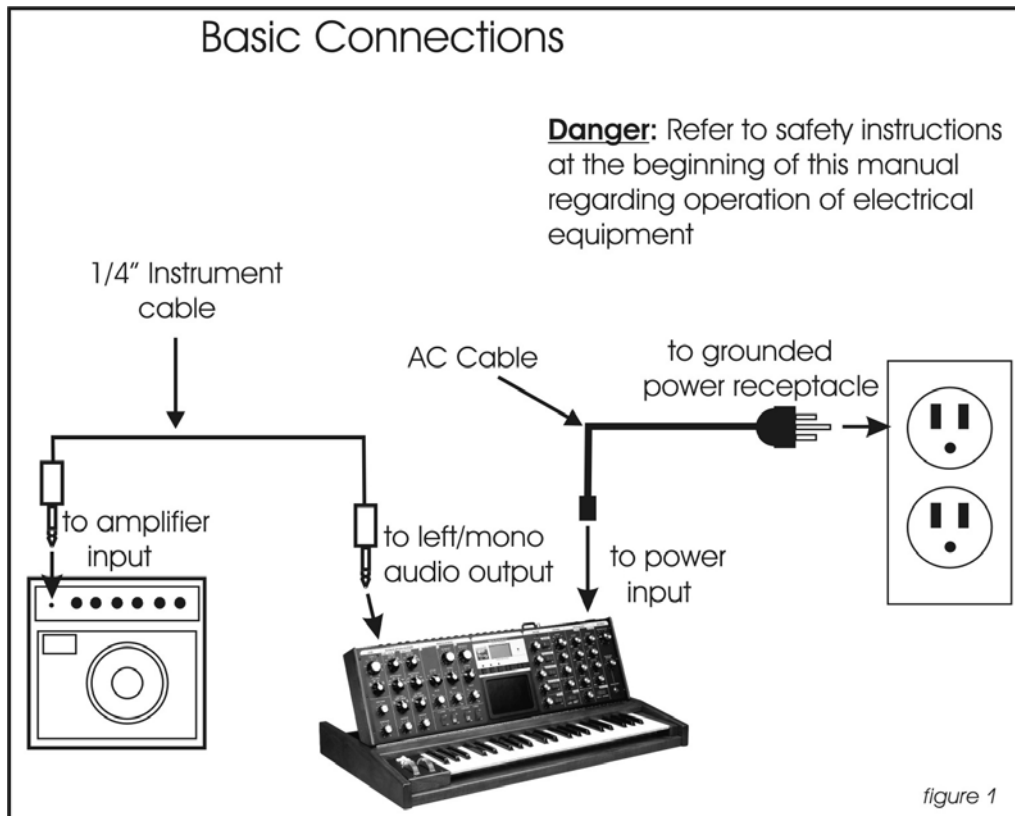

### *-Power up*

Turn the power on. You will see the screen light up and display: "minimoog Voyager by moog music". After about 5 seconds the greeting screen disappears and you will see the current active preset. The LED labeled "PANEL" will be lit. The buttons labeled "PANEL", "EDIT", and "MASTER" access the 3 operating modes of the Voyager.

### *-Connect to Amplifier*

Connect your Voyager to headphones or an amplifier (figure 1). For a mono connection, use the jack labeled "left/mono". To connect the Voyager to a stereo amplifier, use the left/mono and right audio outputs to connect to the left and right inputs of your amplifier. To get a sound, play the keyboard. Adjust the amplifier level until it is at a comfortable level for listening.

### *-Start Playing!*

The quickest way to hear what the Voyager has to offer is to listen to the presets. Pressing the +1 or -1 buttons will access a new preset. If the sound does not change, then "Quick mode" is not active – simply press ENTER to load the new sound. Presets 001 – 128 are loaded with sounds from the factory. There are a total of 128 locations in memory for presets – all are user programmable. Note that once a preset is called up, you can tweak the parameters to your liking. If you make changes to a preset and want to return to the original sound, simply press ENTER. If you want to save your changes – refer to the section on Saving Presets on p. 48. Any changes made to a preset will be gone if they are not saved.

To operate exclusively from the Front Panel and not from the Presets, the actual panel parameters must be loaded. This is done by pressing the EDIT button to enter EDIT mode; then use the +1 button to highlight REAL PANEL CONTROL. Press ENTER, and you will see

the prompt: " Load actual panel parameter? Yes/No". Use CURSOR to select Yes and press ENTER. The sound produced by the Voyager is now determined by the settings of the front panel independently of preset memory.

When working with the Voyager, keep in mind that many of the controls are interactive, so there is frequently more than one way to control a single parameter. For instance, if the sustain level of the Volume Envelope is all the way down, and the attack and decay times are at zero, there will be no output. It is really important to understand the workings of all the controls and how they interact in order to understand *how* a sound (or lack thereof) is produced. The best way to accomplish this is to start with a simple patch, such as the Default Program, shown on p. 47 of this manual. It can be accessed by the Initialize Parameters function in Edit Mode. With this Preset active, a single Oscillator (Osc.1) is the sound source. Try the controls right of the mixer first – one at a time – and notice how they affect the sound. Then try combining different tones with the mixer and Oscillators 2 and 3. Finally experiment with the Mod Busses to see how different types of Modulation affect the sound. To find out how the factory presets are programmed – try the "Parameter Display" function – if you need to turn it on, refer to p.49 of this manual. Go through each control and change it, then see what the stored value is – you will start to get a picture of how that preset is put together.

For a thorough understanding of the Voyager and it's workings, continue on with this manual...

## II. THE BASICS OF ANALOG SYNTHESIS

For those getting started in the world of electronic music, let's take a few moments to go through the basics of sound and synthesis. This will help you understand what the front panel controls do.

In order to understand synthesis, one must have a basic working knowledge of the characteristics of sound. There are a few key terms that cover the basics:

**Sound** – audible vibrations of air pressure. Electronic sounds are delivered to the air through loudspeakers. (figure 2)

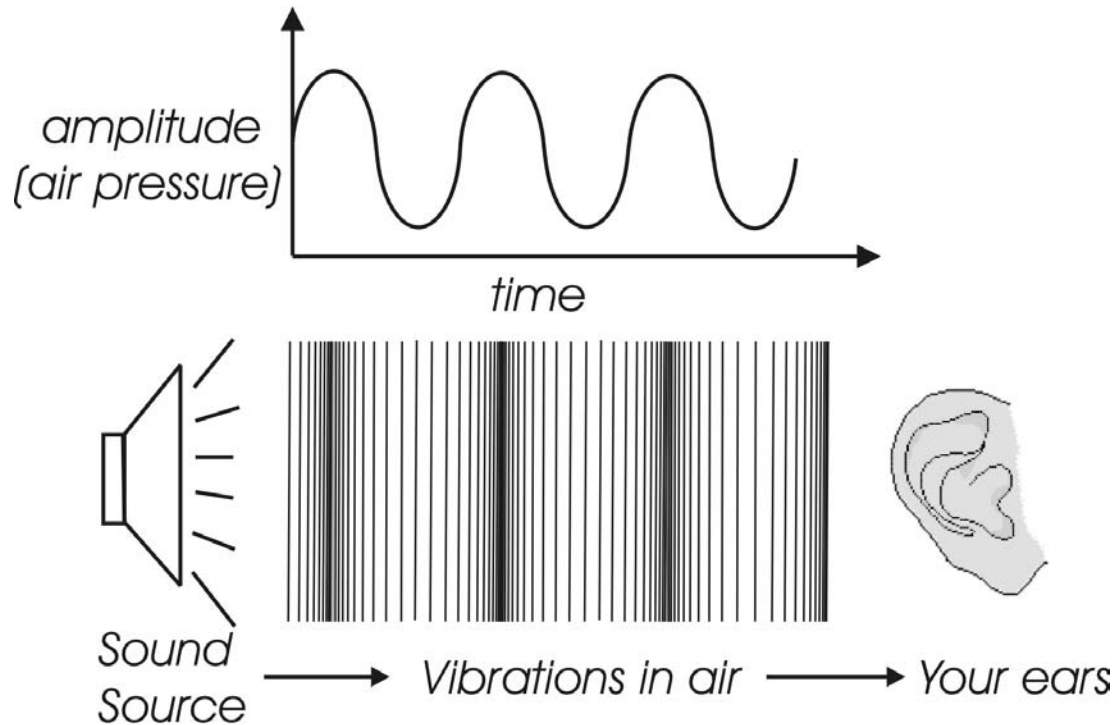

figure 2

**Frequency**– The rate of vibration in sound measured in Hertz (Hz or cycles/second) (figure 3). Our ears can hear from 20 to 20,000 Hz. Frequency corresponds to the musical term, pitch. A low frequency corresponds to a low-pitched sound such as a bass; a high frequency sound corresponds to a high pitched sound such as a piccolo. In music, a change in pitch of one octave higher equals a doubling of the frequency.

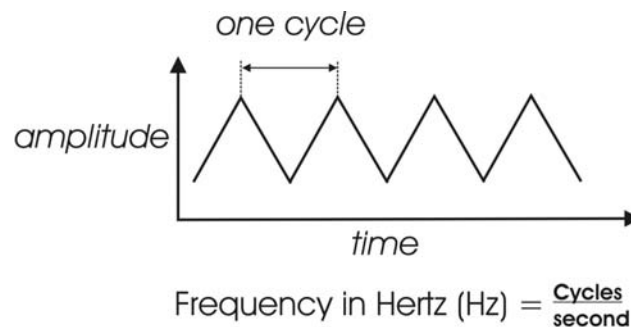

figure 3

**Amplitude** – The strength of a sound’s vibration measured in Decibels (dB). This corresponds to the musical term Loudness (figure 4).

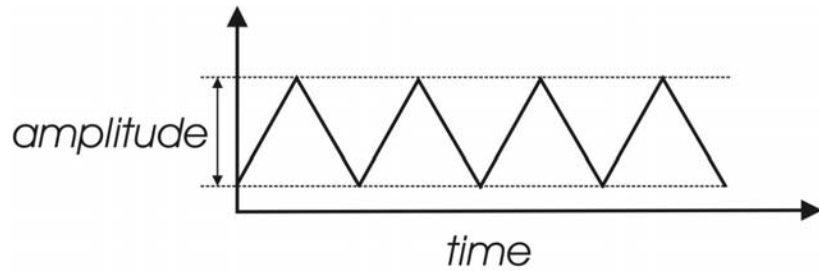

figure 4

**Harmonic Content** – A sound is made up of simple vibrations at many different frequencies (called harmonics) which give a sound its particular character. This corresponds to the musical term *timbre* or *tone color*. A harmonic sound, such as a vibrating string, is one in which the harmonics are mathematically related by what is called the harmonic series. These sounds are typically pleasing to the ear and generally the consecutive vibrations have the same characteristic shape or waveform. An inharmonic sound, such as a crash cymbal, is one in which the harmonics are not mathematically related. Their waveforms look chaotic. White noise is an inharmonic sound that contains equal amounts of all frequencies. A frequency spectrum is a graph of harmonics vs. their amplitude; a waveform is a graph of the amplitude of a sound vs. time (figure 5).

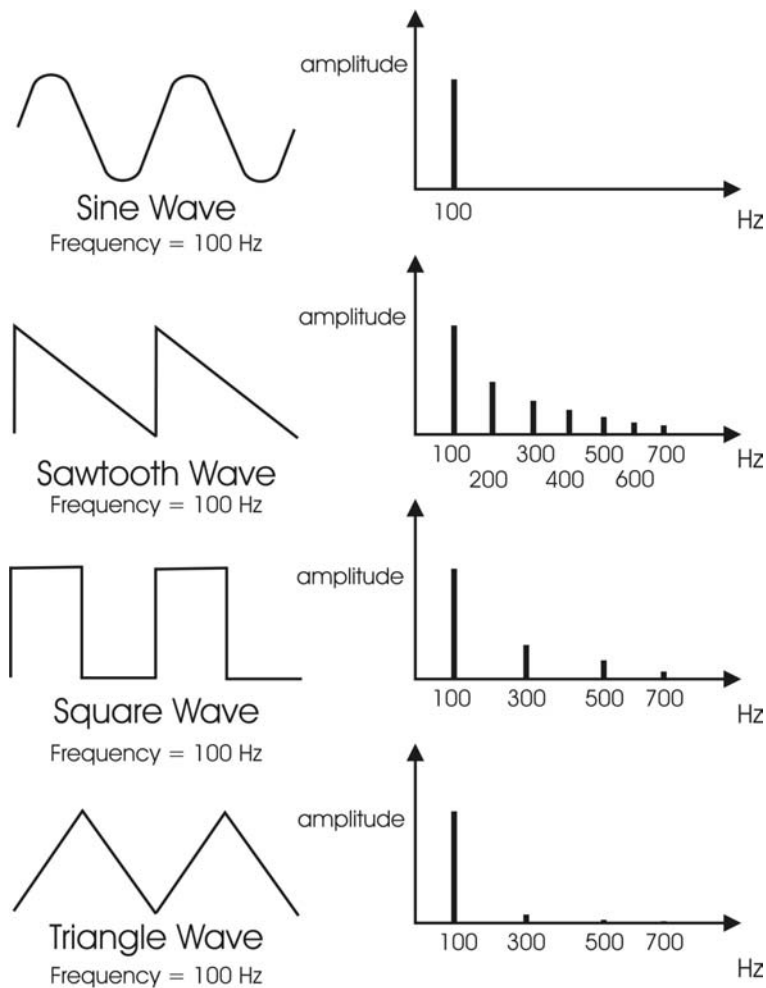

figure 5

In general, "synthesis" refers to the generation of sound through a group of amplified circuits over which the programmer/performer has power to change volume, pitch, timbre and articulation. The Minimoog Voyager is based on what is called "subtractive synthesis". This method of synthesis employs a harmonically rich (think bright-sounding) source material, and then removes frequency components to create the desired sound. The basic components of subtractive synthesis and their definitions follow:

**Oscillator:** A circuit that electronically "vibrates". When used as a sound source, an oscillator is the electronic equivalent of a vibrating reed, or string. When amplified, an oscillator produces a pitched sound whose frequency is determined by one or more control voltages (see below for more info). Changes to these voltages correspond to changes in pitch. An oscillator's vibration can have different shapes or waveforms, which are described below. The Voyager has three oscillators.

**Waveform:** The shape of an oscillator's vibration. This determines its timbre. Commonly used waveforms in subtractive synthesis are sawtooth, triangle, square, or rectangular. Different waveforms have different timbres. A sawtooth has the greatest number of harmonics, and sounds bright and buzzy. A square wave has only odd harmonics, and sounds bright, but hollow, like a clarinet. A rectangular wave can vary in shape, but typically has a bright but thin sound, and a triangle wave's harmonics are so low in amplitude that it sounds muted and flutelike (figure 6).

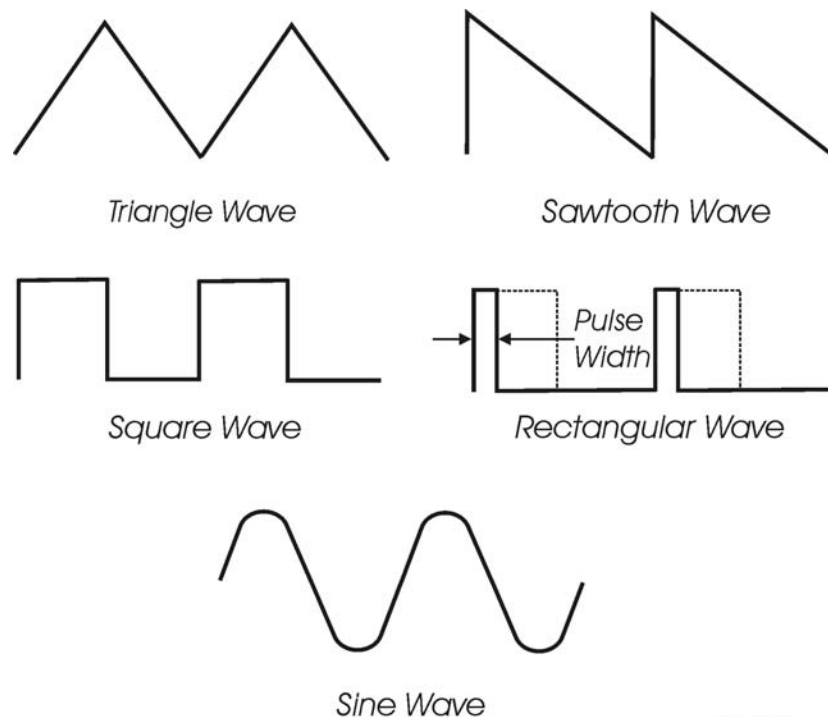

figure 6

**Mixer:** A circuit for combining multiple sound sources or signals. The Voyager's Mixer allows you to select and set the level for up to 5 different sound sources.

**Filter:** A circuit that removes some frequencies and allows other frequencies to pass through the circuit.

A filter has a *cutoff frequency* that determines the point at which frequencies begin to be removed.

A *lowpass* filter is one in which frequencies above the cutoff frequency are removed and all frequencies below the cutoff are passed through.

A *highpass* filter is one in which frequencies below the cutoff frequency are removed and frequencies above the cutoff are passed through.

A *bandpass* filter has two cutoff frequencies that define a frequency band, outside of which the frequencies are removed (figure 7).

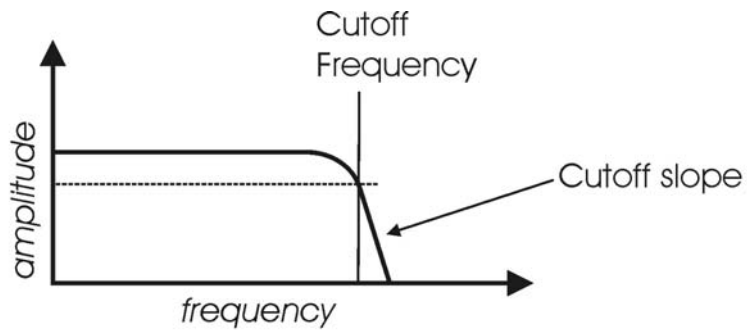

Frequency Response of a Lowpass Filter

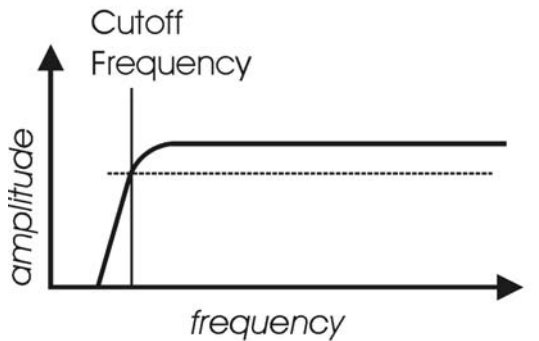

Frequency response of a Highpass Filter

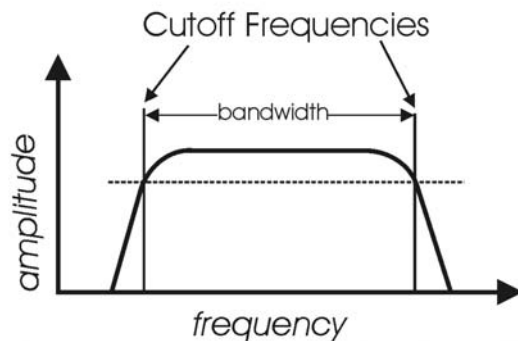

Frequency response of a Bandpass Filter

figure 7

**Control Voltage** - Control voltages (also called CVs) are used in analog synthesizers to affect changes in the sound. In the case of pitch, pressing a key on the keyboard sends a control voltage that determines the pitch of the oscillators. The pitch can also be changed by a voltage provided from a panel control, such as an oscillator tuning control. Every panel control on the Voyager produces a control voltage that is routed to the circuit that the knob or slider is designed to change. An oscillator with pitch varied by the voltage from the keyboard or tuning control is a *Voltage Controlled Oscillator*, or *VCO*. A filter whose cutoff frequency is determined by a voltage provided from the cutoff control is a *Voltage Controlled Filter*, or *VCF*. An amplifier whose amplification is determined by a CV is a *Voltage Controlled Amplifier*, or *VCA*.

To illustrate the idea of control voltages, let's look at a theoretical voltage controlled synth with a VCO, VCF (lowpass) and VCA. Let's suppose that the VCO frequency and VCF cutoff frequency change one octave for every volt applied to their control inputs. Let's also suppose that the VCA output level is at 100% when +5 Volts is supplied to the control input, and is at 0% when 0 Volts is applied. In figure 8a, The VCO oscillates at 500 Hz with a +1 V CV, the VCF has a cutoff frequency of 16 kHz with a +5 V CV, and the VCA produces 100% output with a +5 V. In figure 8b, we reduce the VCO CV to 0 V, a change of 1 Volt. Notice that the frequency is halved – a change of one octave. The VCF CV is dropped 6 volts to -1 V. Notice that the cutoff frequency then drops 6 octaves, and at 250 Hz, only allows the fundamental tone through. Finally, the VCA CV is reduced by 3 Volts. Notice the amplification is reduced to 40% of the maximum level.

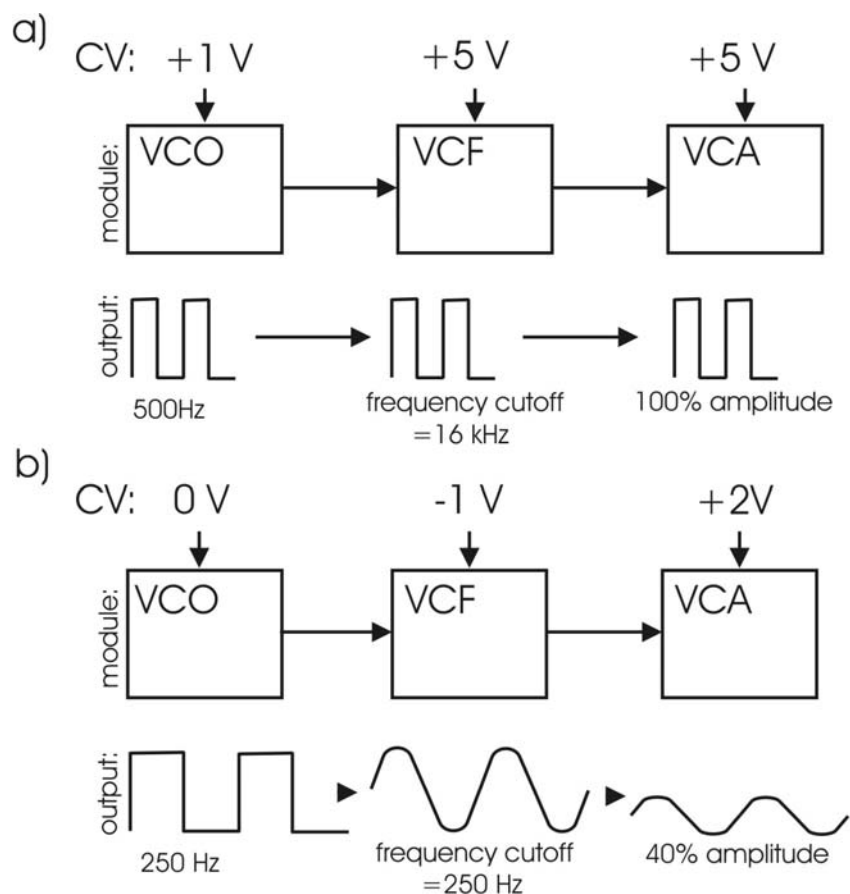

figure 8

**Modulation** - Modulation is the use of a CV to affect a voltage-controlled circuit. Modulation has a source, destination, and amount. This could be as simple as the filter cutoff of a VCF (a modulation destination) being changed by the front panel cutoff control (the source), or as complex as mixing multiple CVs together to modulate filter cutoff. Modulation is used in synthesis to create complex sounds and add variation.

**Envelope Generator** - An envelope describes the contours that affect the characteristics of a sound as it evolves in time from its start to its finish. Take a plucked string for example: when a string is plucked, its amplitude is suddenly very loud, then dies out gradually. The initial part of the sound is very bright but then the brightness fades away. The frequency of the sound goes slightly higher and then drops slightly as the note fades. These kinds of changes in a sound over time can be applied to oscillators, filters or the amplitude of an electronically generated sound by an envelope generator. The envelope generator creates a CV that describes the contours of a sound. *Attack*, measured in time, specifies the onset or transient of a sound. With Volume for instance, the sound might start suddenly as does a plucked string sound, or fade in slowly like a bowed string crescendo. *Decay* is also measured in time and specifies how quickly the onset of a sound fades into the sustained portion. *Sustain* is the level at which a sound sustains after the initial transient. *Release* is measured in time and determines how long a sound takes to fade away after a note is released. These four components make up an ADSR envelope generator. An envelope control signal has to be started and stopped. The start and stop is triggered by what is called a *gate signal*. A gate signal is either on or off. When it goes on, the Envelope generator is started, when the gate goes off, the release segment of the envelope begins. (figure 9)

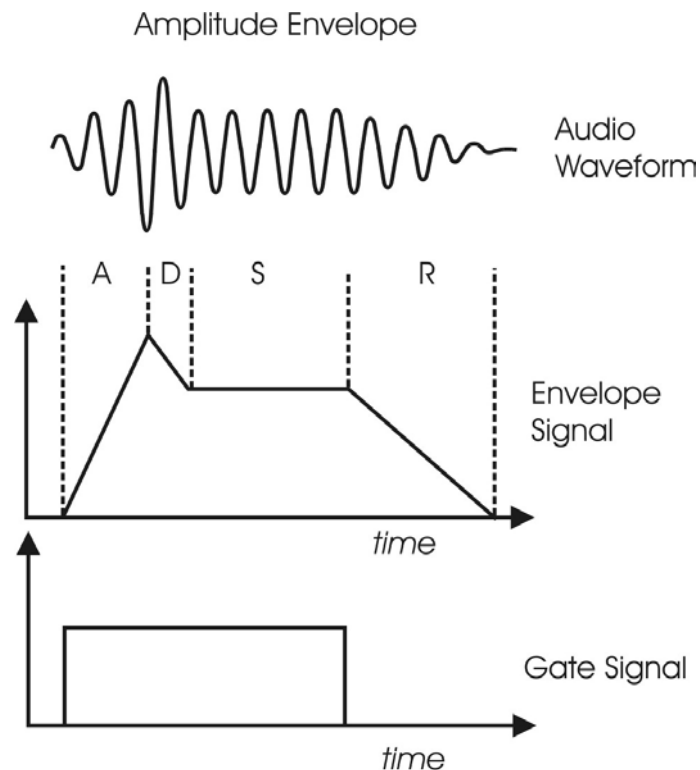

figure 9

**Low Frequency Oscillator** - Also called an *LFO*, this is a special type of voltage controlled oscillator that oscillates primarily below the range of human hearing. LFOs are typically used as a source of modulation.

For instance - an LFO with a triangle waveform at about 6 Hz modulating the pitch of a VCO sounds like vibrato. The same LFO with a square wave will sound like a trill (figure 10). An LFO modulating a voltage controlled amplifier will sound like a tremolo.

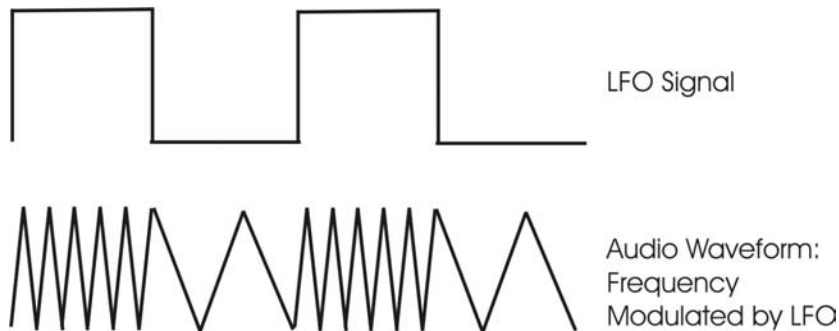

figure 10

**Sample and Hold** - This is a circuit with an input for a control voltage and an input for a trigger. Each time the trigger is fired, the circuit takes the voltage that appears at the input and holds it at the output until the next time the circuit is triggered.

An LFO is a common way to trigger a sample and hold (or S&H) circuit. When an LFO is applied to the trigger input, and a random signal such as white noise is applied to the CV input, a random stepped voltage will appear at the output in time with the each cycle of the LFO. (figure 11)

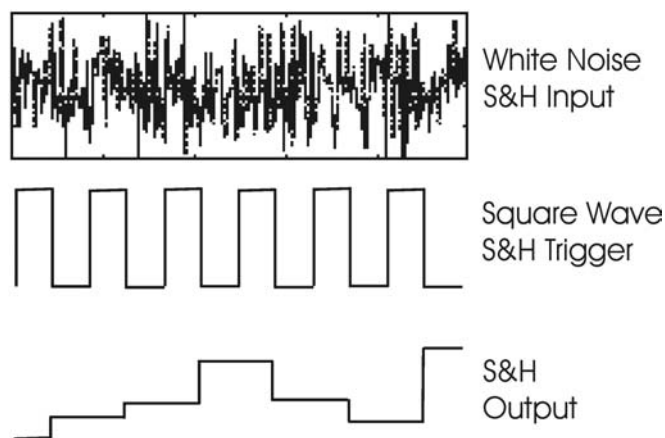

figure 11

**Glide** - Also called portamento, is the slowing down of pitch changes as you play different notes on the keyboard. In synthesizers, a rate is specified that determines how fast the glide between notes is.

These terms are basic to understanding analog subtractive synthesis. Should you choose to pursue a more in depth study of the subject, recommended is the book [Analog Synthesis](#) by Reinhard Smitz, available from Wizoo Publications ([www.wizoo.com](http://www.wizoo.com)).

### III. The Voyager's Features

The minimoog Voyager is a monophonic analog synthesizer that is a descendant of the classic minimoog. Its sound sources are an external audio input, a noise source, and three analog, variable waveform oscillators. The Voyager has front panel controls for real time control of its parameters (figure 12).

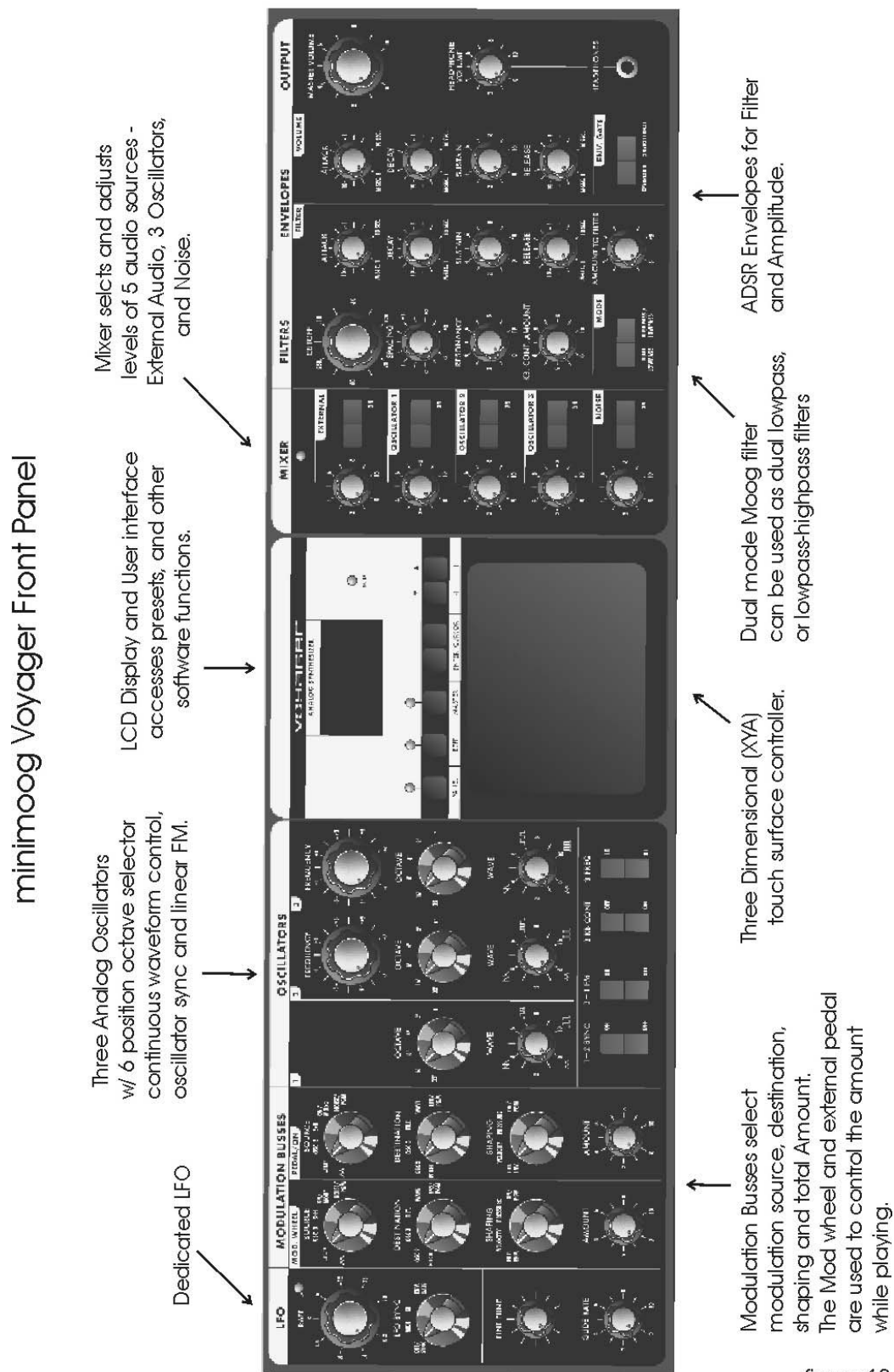

figure 12

The back panel offers the many connections available, including the power, MIDI, CV, and audio connections (figure 13). For the Control Inputs, a blue nut indicates a gate/footswitch input and a red nut indicates a CV/ expression pedal input.

Minimoog Voyager Back Panel

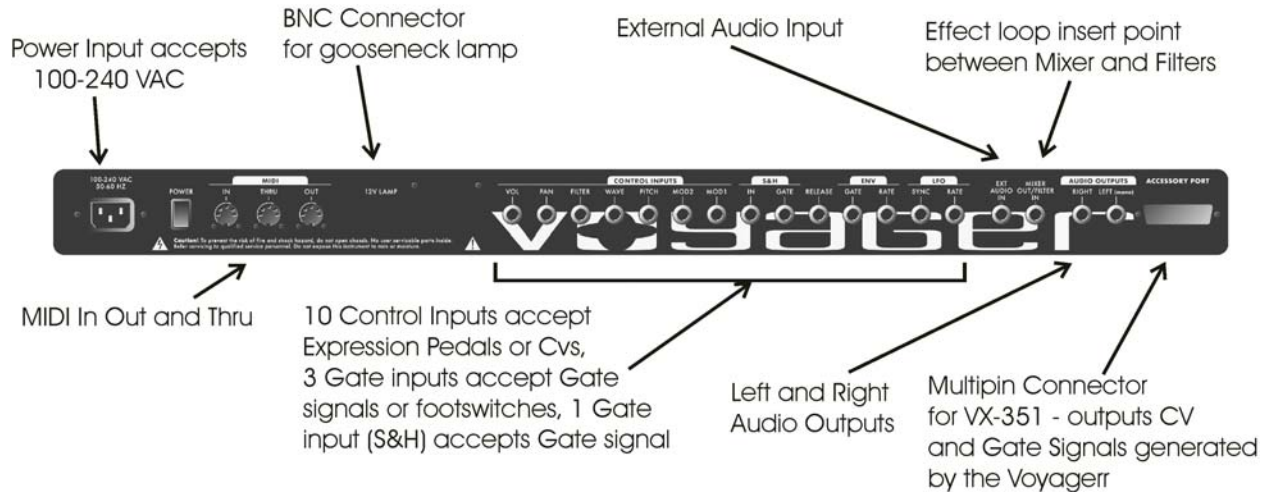

figure 13

- The Oscillator section includes controls for choosing the octave, the tuning of the second and third oscillators, the oscillators' waveforms, and switches for oscillator sync, linear FM, and oscillator 3's frequency range and keyboard control.
- The sound sources are selected and their levels are set in the Mixer section. The output of the Mixer section goes to the Filter section. An effect can be inserted between the Mixer and Filters by means of the Mix Out/ Filter In jack.
- The Filter section contains two filters that work together in two different modes. Dual Lowpass mode features two lowpass filters in parallel and Highpass-Lowpass mode features a lowpass and highpass filter in series. The Cutoff control affects both filters' cutoff frequencies, and the Spacing control sets a difference between the two filters' cutoff frequencies. The outputs of the Filters are passed on to the Output VCAs.
- The Envelopes section contains one ADSR envelope generator for the Filters, and one ADSR envelope generator for the Output VCAs. The audio path is illustrated in figure 14.

Voyager Audio Signal Path

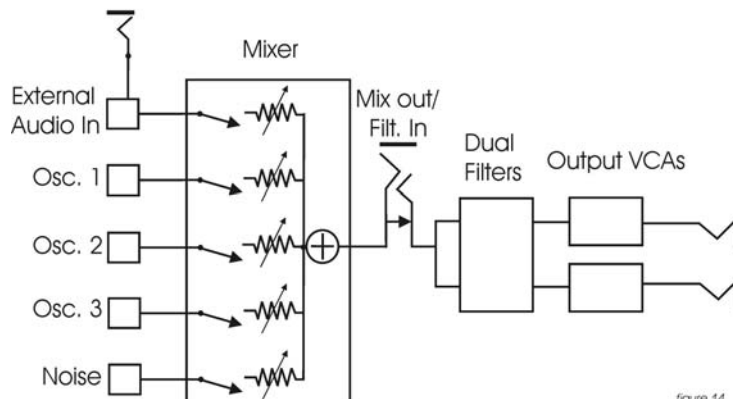

figure 14

### Control Signal Path: VCOs, VCFs, VCAs, and EGRs

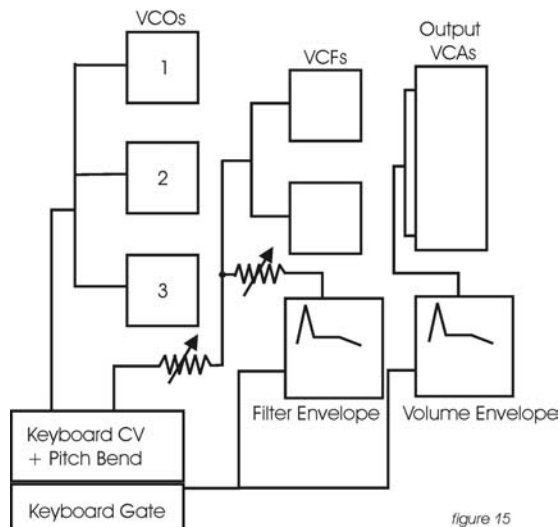

figure 15

- When a key is pressed, A Gate and Pitch CV are produced by the keyboard. The Gate signal is used to trigger both the Filter and Volume Envelopes. The Pitch CV is used to determine the pitch of the Oscillators and can be applied to a varying degree to the Filters through the Keyboard Control Amount knob.

- Modulation is performed through the Modulation Busses. There are two separate Mod busses. One is controlled by the Mod Wheel, while the other is controlled by the MOD1 CV input. If nothing is plugged into the MOD1 CV Input, then the PEDAL/ON bus is on at the level determined by the Amount control. In each Mod Bus, a Modulation Source, Shaping signal and Destination are selected. An overall maximum modulation amount can be set with the Amount control. The Modulation CV paths are illustrated in figure 16.

### Control Signal Path: Modulation Busses

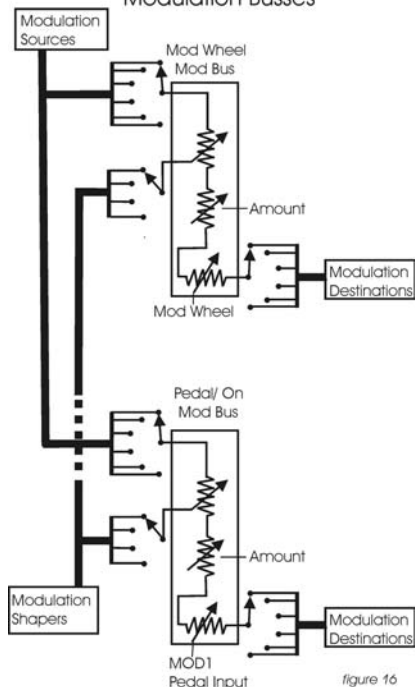

figure 16

- The LFO is assigned through the MOD Busses. It features a triangle and square wave. It is also used to trigger the Sample and Hold.

- The touch surface controller can control three parameters (X,Y,A) simultaneously. The position of a finger on the touch pad generates a control voltage for horizontal (X) position and a control voltage for vertical (Y) position. Pressing on the touch surface causes a CV based on the area (A) of the fingertip. A light touch causes less of your fingertip to touch the pad, a heavy touch causes more contact with the touch surface.

## IV. The Voyager's Components

### A. MIXER

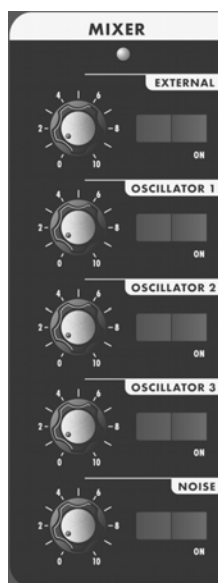

The Mixer combines the main sound sources of the Voyager. It's the place to start when creating a new sound from scratch, or figuring out how a sound is put together. All the sound sources can be turned on or off, and their levels can be adjusted. The sound sources available are:

- External Audio Input
- Oscillator 1
- Oscillator 2
- Oscillator 3
- Noise Source

Each sound source has both an on/off switch and a level control. When working with the Voyager, it is important to keep track of which sound sources are on and which are off.

The audio output of the mixer goes to the filter. There is an insert jack on the back of the unit where an external effect can be inserted in between the mixer and the filter. This can also be used as direct output of the Mixer. Note that this output is before the Volume envelope. If an Oscillator is selected and its level is above zero – its sound will be there regardless of playing the keyboard.

**OSCILLATORS 1 to 3:** The controls for the Oscillators on the mixer are simple: on/off and level. When the levels of the Oscillators are set high, the output from the mixer gently overdrives the filter section. This was one of the important features in the original minimoog that gave it its characteristic “fat” sound.

**NOISE:** The Noise source is a white/pink hybrid, and can be used as a sound source or a modulation source.

Noise is great for making ocean wave sounds, explosions, wind sounds or using as a subtle coloration to a sound.

**EXTERNAL AUDIO IN:** The External Audio in allows an external audio source to be routed into the mixer, where it can be mixed with the VCOs and Noise source, then passed to the filters and the out put. The LED above the External input begins to light up as the Input signal to overdrives the Mixer input. When the light is faint, a small

amount of soft clipping is occurring. When the LED is bright, the signal is really strongly overdriven. Judicious use of overdrive can really fatten up a sound. The external audio input can accept a signal from instrument level to line level.

**MIX-OUT LOOP:** The jack on the back labeled "mix out/filter in" is an insert point between the Mixer output and the filter input. Using a standard insert cable an effect such as a moogerfooger MF-102 Ring Modulator can be inserted to add effects to the oscillator, noise source, and external audio in prior to the filter stage. The Mixer output signal send appears at the tip of the jack. The return signal appears at the ring of the jack. A cable plugged into the jack breaks the connection between the mixer and the filter, Unless the Return signal is sent to the ring of the jack, no signal will pass through to the filter. The level settings in the mixer affect the output level, so keep this in mind as you try different devices in this loop. This insert point is a great spot to insert a distortion or waveshaping device, a phaser, ring modulator, or delay effects (figure 17).

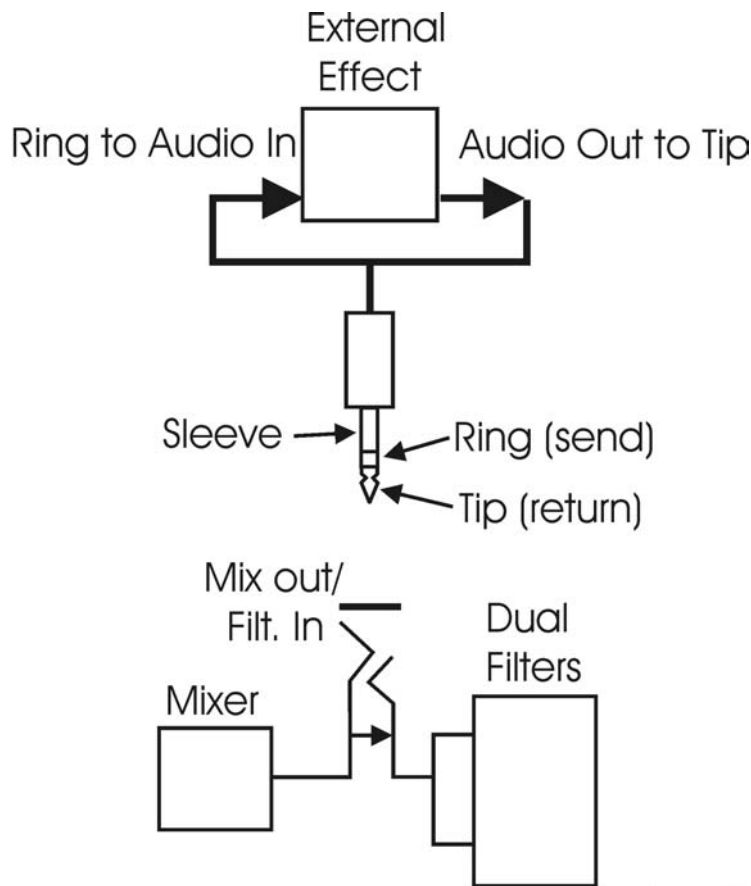

figure 17

## B. OSCILLATORS



The Oscillators are the main sound source of the Voyager. The oscillators in the Voyager are all analog Voltage Controlled Oscillators, or VCOs. They feature a temperature regulation circuit that provides them with excellent tuning stability. The VCOs can produce a total musical range of 8 ½ octaves! In addition, the frequency of oscillator 3 can be set to sub-audio (<20Hz) vibrations for use as a second LFO.

Oscillator One performs as a master oscillator to which Oscillator 2 and 3 are tuned. The timbres of the oscillators are adjusted by their variable Waveform controls. In addition, there are switches for Oscillator 2 sync to 1; Linear Frequency modulation of oscillator 1 by 3; Oscillator 3 keyboard control on/off; and Oscillator 3 Lo or Hi frequency range. The frequencies of the Oscillators are controlled by a number of sources. The main source is the keyboard. The keyboard outputs a voltage that allows the oscillators to be played in an equal tempered scale. The glide circuit can be switched in between the Keyboard CV and the oscillators to slow the changes between notes. The Keyboard CV is mixed with the Octave switch CV, the Frequency control (oscillators 2 and 3), the Pitch Bend Wheel, the Pitch CV In (on the back panel), the fine tune control, and the output of the Mod Busses when the "Pitch" destination is selected.

**OCTAVE:** Oscillator Octave switch (6 positions)

Each Oscillator has a switch labeled Octave that selects the relative frequency range. To hear how it works, turn off oscillators 2 and 3 with the mixer. Turn Oscillator 1 on and set its level to 5. Play a note on the keyboard and rotate the Oscillator 1 octave switch clockwise one click – the note will rise an octave. You can use this control to change the frequency range that the keyboard controls. The markings 32' up to 1' are octave standards based on organ stops. On the 16' setting the highest A on the keyboard should be A440.

**FREQUENCY:** Oscillator 2 and 3 Frequency control

Oscillators 2 and 3 have a Frequency control. When the control is in the center position, the oscillators should be in tune with the frequency of Oscillator 1 (when the octave switches for all three oscillators are in the same position). The frequency control can change the pitch of oscillator 2 or 3 a total of + or – 7 semitones

relative to Osc. 1. This allows more than one frequency to be played when a key is pressed, or to get a very swirly sound when the oscillators are slightly out of tune. Oscillator 1 does not have a frequency control because it is designed to serve as a reference oscillator for the other 2 oscillators.

### FINE TUNE:

Fine tune control can be used to tune the Voyager's oscillators + or - 2 semitones for matching an external reference pitch.

### WAVE: Oscillator waveform control

The VCOs of the Voyager feature a continuously variable waveform control. The legend on the front panel shows the pure waveforms that are available. They are triangle, sawtooth, square, and rectangular. The waveform is morphed gradually from one to another as the waveform control is rotated. Because the waveform is voltage controlled, this can be modulated. This allows generation of some very interesting timbral changes. By limiting the modulation between the square and skinny pulse waveform, you can get pulse width modulation. Although the waveforms can be set from the front panel individually for each oscillator, modulation is applied to all three waveform controls simultaneously. When using modulation, it is possible to make the width of the rectangular wave so skinny that it becomes silent.

### 3 KB CONT: Oscillator 3 Keyboard Control On/Off

The 3 KB Control switch, located below the oscillators disables keyboard control of oscillator 3's pitch when in the off position. By disabling the keyboard control of Osc. 3, you can use it as a drone, or as a modulation source whose frequency doesn't change with the key played. In addition to turning off the keyboard control of Oscillator 3, switching this to OFF increases the amount the Oscillator 3 FREQUENCY control changes Oscillator 3's frequency.

### 3 FREQ: Oscillator 3 Frequency range switch Lo/Hi

This selects Oscillator 3's frequency range. When in the Lo position, Osc. 3 operates as a subaudio sound source (clicks) or as a modulation source (LFO). When in the Hi position, Osc. 3 operates with the same available frequency range as Osc. 2.

### 1 → 2 SYNC: Oscillator 2 Synced to Oscillator 1

Oscillator Sync is an effect caused by resetting an oscillator waveform's start point with another oscillator (figure 18). The effect is noticeable if The Synced Oscillator is a higher frequency than the Reset Oscillator. The main frequency heard is that of the reset oscillator. As the frequency of the synced oscillator is swept, it reinforces the harmonics of the reset oscillator. Depending on how applied, the effect can be aggressive or warm and vocal. This effect is much more dramatic when Oscillator 2 is set to a higher octave than Oscillator 1.

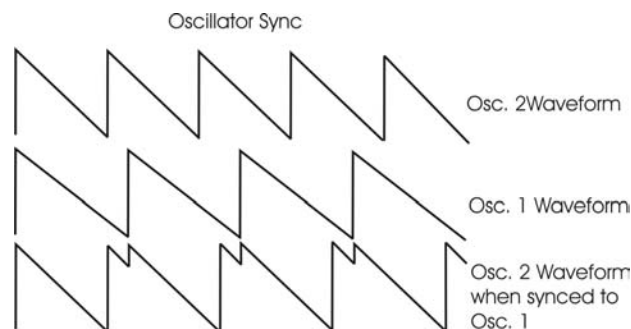

figure 18

### **3 → 1 FM:** Direct Linear Frequency Modulation of Osc. 1 by Osc. 3

When an Oscillator is used as a CV source for another VCO, it is called Frequency modulation. Frequency Modulation effects can vary from vibrato or trill effects to clangorous inharmonic sounds to rich timbres that evoke acoustic sounds. Linear FM is the kind of Frequency Modulation used in classic FM synths.

**GLIDE:** Glide enables a glissando effect between notes. There is a switch on the left hand controller panel that enables this effect. The knob labeled glide adjusts the rate of glide. The glide can vary from a very fast to a very slow glide.

**CONTROL INPUTS FOR THE OSCILLATOR SECTION:** There are two inputs on the back panel that accept CVs or expression pedals that affect the oscillator section. They are labeled Pitch, and Wave. The Pitch input controls the frequencies of all three oscillators. A one volt change of this voltage will change the pitch by approximately one octave. The Waveform input controls the waveforms of all three oscillators. A 5 Volt Change of this voltage will sweep the oscillator waveforms through their entire range. Plugging in an expression pedal like the moogerfooger EP-1 (ring = +5.5 supply to the pedal, tip =variable CV return) produces control voltages from 0 V to +5 V at either control input.

## C. FILTERS



Ahh... the Moog filter – the sound that started it all... Filters are used for transforming the character of an audio signal. Filters are used to modify a sound by stopping some frequencies and allowing others to pass through. An important term regarding filters to understand is “Cutoff Frequency”. This is a frequency at which frequencies begin to be rejected. There are different types of filters. Some of the most common and most musically useful are lowpass, highpass, and bandpass. A lowpass filter behaves as its name indicates: it allows low frequencies through and rejects high frequencies. A highpass filter does the opposite. It passes all frequencies above the cutoff and rejects the frequencies below the cutoff. A bandpass comes from a lowpass and highpass filter put together. The lowpass filter defines a maximum frequency that will pass through, and the highpass filter defines a minimum frequency that will pass through. What’s left is a band of frequencies that will pass through the filters, hence the name, bandpass.

Another aspect of filters is their cutoff slope. This refers to how many dB per octave frequencies are rolled off beyond the cutoff frequency. The number of “poles” in a filter determines the cutoff slope. Each pole adds 6dB to the cutoff slope. Therefore a 1-pole filter rolls off frequencies at 6dB/octave, a 2-pole filter has a 12dB/octave cutoff slope, 3 poles makes for a 18dB/octave cutoff slope, and a 4 pole filter has a 24dB/octave cutoff slope. The classic Moog filter is a 24dB/octave lowpass filter.

With the Resonance control, a peak is created at the cutoff frequency (fig. 19).

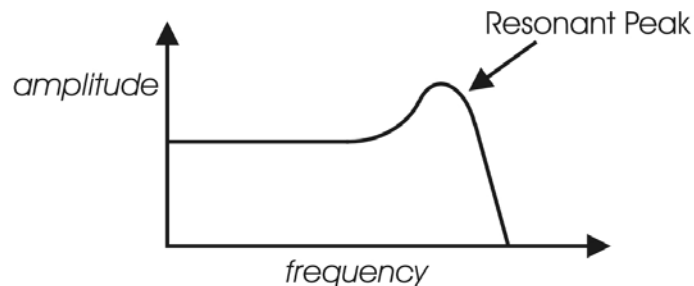

Frequency response of a Lowpass filter with Resonance

figure 19

When the resonant peaks of the lowpass filters pass through the overtones of the sound being filtered, those overtones are reinforced. This gives the filter a nice character that sounds vocal, quacky, or zappy, depending on how it's used. When the resonance is turned up past 8, the filters begin to self-oscillate at the cutoff frequency, producing a sine wave tone. The Keyboard Control Amount control sets how much the filters' cutoff frequencies track the keyboard note that is played. As you play higher on the keyboard, the cutoff frequency goes higher, too.

The Voyager features two filter modes: Dual Lowpass and Highpass/Lowpass

#### DUAL LOWPASS MODE:

The Voyager's dual Lowpass filter mode features two lowpass filters which are routed to the left or right audio output. The Cutoff knob controls the frequency cutoffs of both filters. The filters can be set to the same cutoff frequency, or different cutoff frequencies with the Spacing control (figure 20). When the two filters are set at different cutoff frequencies and routed to two different speakers, what you hear is a fantastically swirly and vocal sound – halfway between a phaser and a lowpass filter.

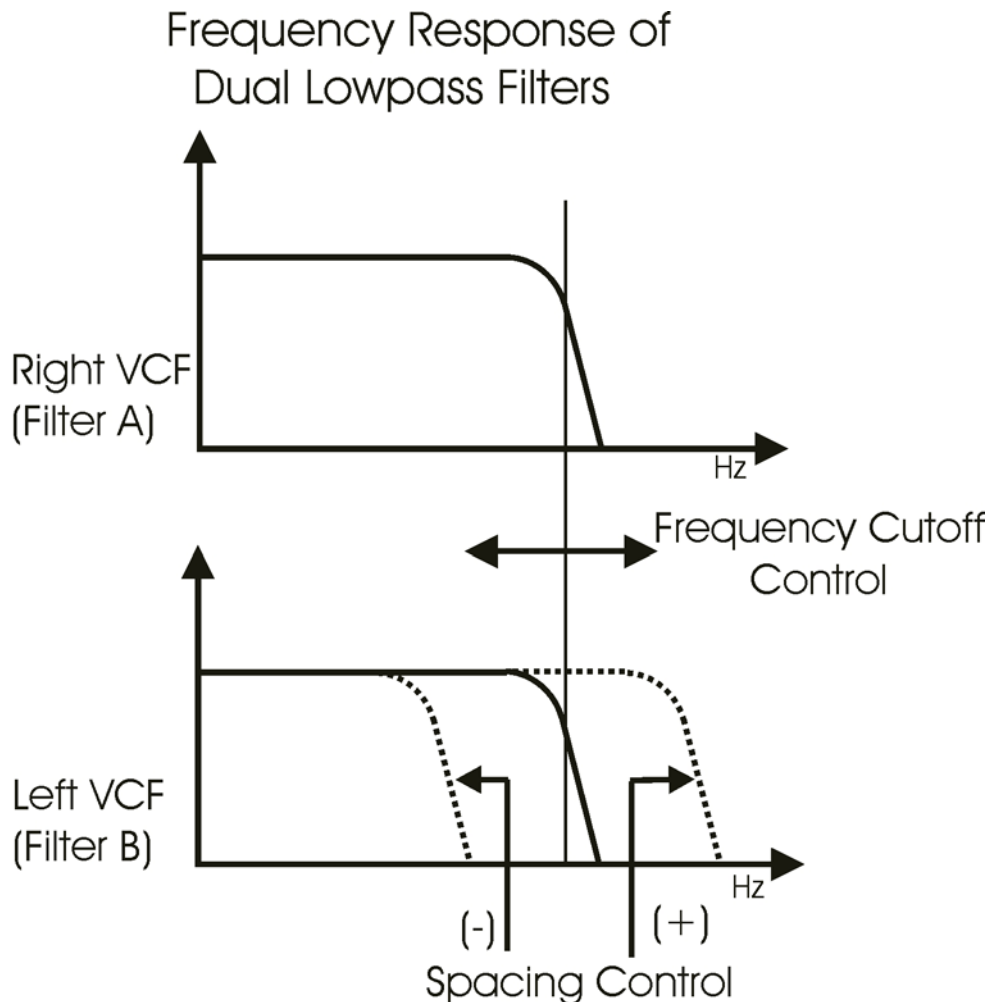

figure 20

### HIGHPASS LOWPASS MODE:

In Highpass/Lowpass mode, the Voyagers filters are configured as a lowpass and highpass filter in series, summed to both outputs. As with the dual lowpass mode, the Cutoff control changes the cutoff frequency of both filters, and the spacing sets the frequency difference between the highpass filter and lowpass filter. The spacing between the two filters creates a bandpass filter (figure 21). The Resonance control affects only the lowpass filter, thus making for some terrifically interesting filter sounds.

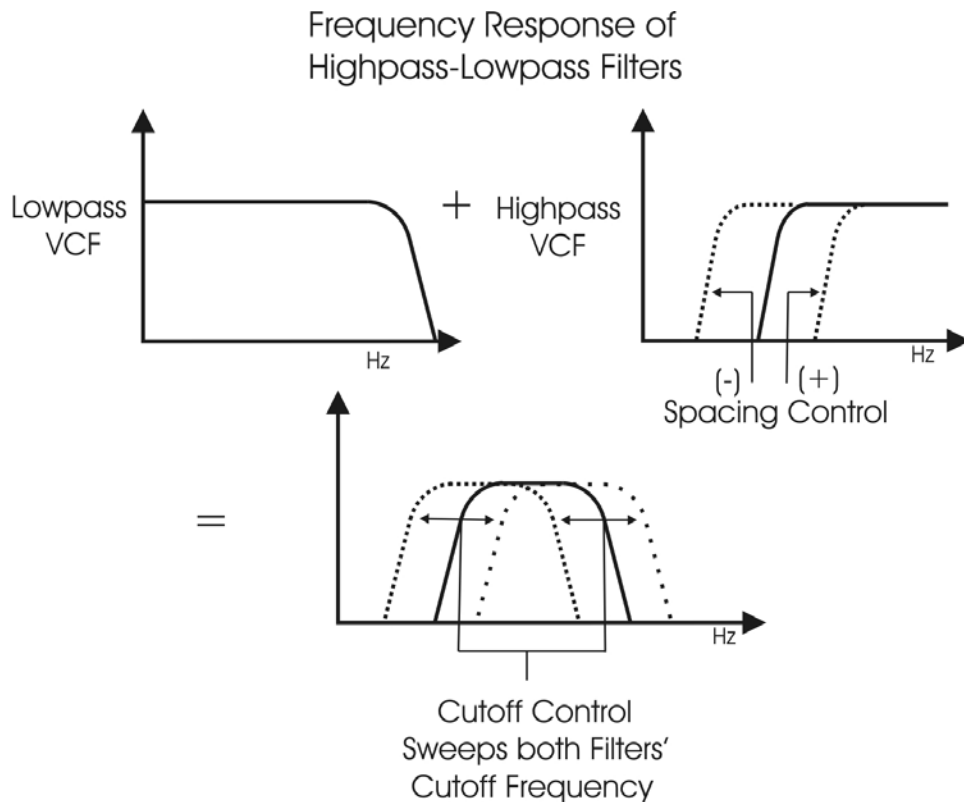

figure 21

### CUTOFF:

The Cutoff knob is the main filter control. This sets the cutoff frequency of both of the filters in the both dual lowpass and highpass/lowpass mode.

In Dual Lowpass, the frequencies to the right of the indicator on the knob are the frequencies that are filtered out. The frequencies to the left of the indicator are the frequencies that are allowed to pass through the filter. This is why as you turn the control clockwise the cutoff frequency becomes higher and the sound becomes brighter. Of course to hear the effect of a lowpass filter it helps to have a signal rich in harmonics which provides high frequencies to filter. A good example of a sound rich in harmonics is a sawtooth waveform.

In Highpass/ Lowpass mode, the combination of highpass and lowpass filters forms a bandpass filter. The Cutoff control changes the center frequency of the passband.

### **SPACING:**

The Spacing control is used to determine the difference between the cutoff frequencies of the two filters in both dual lowpass mode and highpass/ lowpass mode.

In Dual Lowpass mode, the numbers on the legend around the knob refer to octaves. When the Spacing control is centered, the cutoff frequencies of the two filters are identical and the filter sounds like a classic Moog Filter. Setting the Spacing control to +1 in Dual Lowpass mode means that the right filter has a cutoff frequency equal to where the Cutoff knob is set, and the left frequency has a cutoff frequency that is one octave higher than the right filter. This means when the Cutoff control is swept, two resonant peaks are heard, giving the filter a unique quality.

In Highpass/Lowpass mode, the Spacing control sets the difference between the cutoff frequencies by shifting the highpass filter's cutoff frequency up or down. When the Spacing control is fully clockwise, the cutoff frequencies of the two filters are the same, making for a very narrow frequency band.

### **RESONANCE:**

The Resonance control causes feedback in the filter circuit that adds harmonic emphasis at the cutoff frequency. This control affects the lowpass filters, but not the highpass filter. When the Resonance control is all the way down, the lowpass filters act as a tone control, rolling off high end as the Cutoff control is turned down. As the resonance increases, the filter begins to form a peak at the cutoff frequency. As the Cutoff control is swept the peaks reinforce the harmonics of the signal being filtered are reinforced – creating an effect that is vocal or zappy. As the Resonance is turned up the peak increases in strength until the control is set to 8 or higher, when it begins to self-oscillate – creating sine waves with the same frequency as the cutoff frequency.

### **KEYBOARD CONTROL AMOUNT:**

The Keyboard Control Amount knob allows the Filter Cutoff to follow the key played on the keyboard. A higher key will cause a higher cutoff frequency. This allows a sound to retain its brightness as it is played higher on the keyboard.

**FILTER CONTROL INPUT:** The Control Input on the back labeled FILTER is a CV input for external control of the Voyager's filter cutoff control. The Input accepts -5 to +5 volts, or an expression pedal like the EP-1. The voltage applied here is added to where the front panel Cutoff control is set. A one-volt change in this control voltage will change the cutoff frequencies of both filters by about one octave.

**FILTER POLES:** Each Filter's Cutoff Slope can be changed. Select 1 pole (6 dB/Oct.) 2 pole (12 dB/Oct.), 3 pole (18 dB/Oct.) or 4 pole (24 dB/Oct.). This can be done in EDIT mode, with the items "Filter A Poles" and Filter B Poles".

## D. ENVELOPES



When we think of a musical sound, say a plucked string, we think of it as having a start and an end. In the case of a plucked string, it begins with a burst of energy and then slowly fades out until it is silent. In synthesis terms, this is called an envelope – a shape that defines the changes that occur in a sound over time. An envelope can define any aspect of a change in sound – volume, timbre, or pitch for example. The Voyager has two envelope generators. When triggered, these circuits produce control voltages that vary as determined by the attack, decay, sustain and release controls. The Attack control determines the character of the onset of the sound. A short attack time corresponds to a sudden sound like a percussion instrument or a plucked string. A long attack time corresponds to a gradual onset of sound like a plane flying overhead, or the slow crescendo of a bowed string instrument. The Decay is the second stage in the evolution of a sound before it sustains or dies out. For instance with a plucked string – the sound begins with a burst of energy which begins quickly, then drops back to a lesser level of energy and then proceeds to fade out from there. The decay is the time that it takes for the signal to drop down to the level set by the Sustain control. The decay time has no effect when the sustain level is set at 10. As long as a key is held down, the note will sustain at the sustain level. After the key is released, the Release time determines how long it takes for the sound to fade out. An envelope can be used to describe the shape of the volume of a sound, it can also be used to describe other aspects of sound – say timbre or pitch. An envelope is used to generate the evolution of the sound after the note begins.

The Voyager has two envelope generators, one for modulating the filter, and one for modulating amplitude. The envelopes can also be used as Modulation sources or Modulation shaping for other parameters through the Mod Busses.

**ATTACK:** This control sets the Attack time of the EGR from 1 msec to 10 seconds.

**DECAY:** This Control sets the Decay time of the EGR from 1 msec to 10 seconds.

**SUSTAIN:** This is a level control for the sustained part of the envelope.

**RELEASE:** This is the time for the envelope to return to zero, from 1 msec to 10 seconds.

#### AMOUNT TO FILTER:

For the filter envelope, there is a control that adjusts the amount that the filter envelope signal modulates the filter. It has both positive and negative values. If it is set to a positive value, say +2, The envelope will add to the Cutoff control. If it is a negative value, say -2, the envelope will subtract from the Cutoff control.

#### KEYBOARD/ ON/EXTERNAL:

The Envelopes are started by a gate signal. The envelopes will sustain as long as a gate signal is still present. When the gate is off, the release of the envelope happens. The Switch labeled Keyboard/ On/External selects whether the envelopes are triggered from the keyboard, on, or from an external trigger source. When Keyboard triggering is selected, the envelopes are triggered from the keyboard gate signal. When the switch is set for On/ external, the Envelopes are on if nothing is plugged into the external trigger input. In this case the envelopes sustain at the level determined by the sustain controls. This is useful for keeping the envelopes sustaining without holding a key down when you want to process an external audio signal through the filters with out using the keyboard, or create drones. When On/external is selected and a footswitch or external gate signal is applied to the envelope gate input on the back panel, the envelopes are triggered from that input.

**RATE CONTROL INPUT:** The Control Input on the back labeled RATE is a CV input for external control of the Voyager's Envelope time constants. The Input accepts -5 to 5 Volts, or an expression pedal like the EP-1. An expression pedal or a positive voltage applied here *decreases* the attack, decay, and release times from where the front panel is set for both the filter and the volume EGRs. A negative voltage will *increase* the attack, decay, and release times from where the front panel is set for both the filter and the volume EGRs (figure 22).

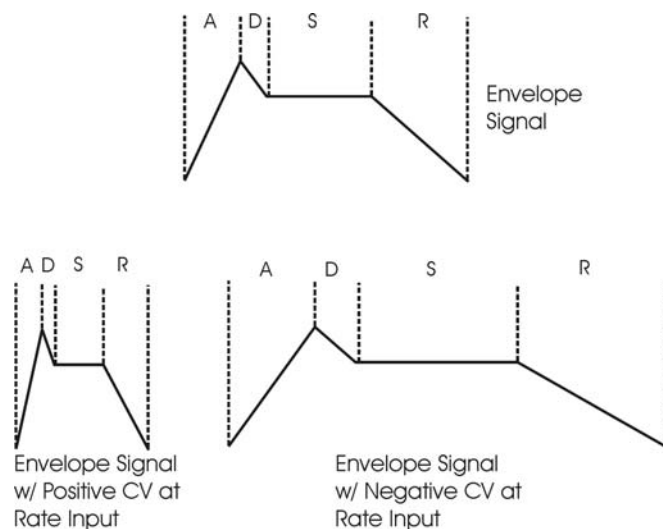

figure 22

**ENVELOPE GATE INPUT:**

This input accepts a footswitch or gate signal. Pressing the footswitch or applying a gate signal (+5V) triggers both envelopes when On/External is selected by the ENV. GATE switch.

**RELEASE INPUT:**

This input accepts a footswitch or gate signal. Pressing the footswitch or applying a gate signal (+5V) enables the Release of the Envelopes regardless of the position of the Release switch on the Left Hand Controller panel.

## E. MAIN OUTPUT



The Voyager has two audio outputs. There is a VCA for each output, which allows for stereo effects such as Panning or the Dual lowpass filtering. The main control for the Volume is the Master Volume Control. The Volume Envelope modulates the output VCAs. When only one output is desired, the two output VCAs are mixed to the left output.

**LEFT/MONO and RIGHT OUTPUTS:** These are the audio outputs that are on the back panel. They are both  $\frac{1}{4}$ " unbalanced outputs. When only the left audio output has a plug inserted into it, both the left and right signals are summed to that jack in mono.

**MASTER VOLUME:** This is the main Volume control. Full-clockwise is maximum output, full-counterclockwise silences the Voyager.

**VOLUME CONTROL INPUT:** Accepts a 0 to 5 V control voltage or an Expression pedal, such as the EP-1 with the ring connection supplying 5 Volts to the Pedal and 0 to 5 Volts control voltage return to the Voyager on the tip connection. The Master Volume sets the maximum output level, and as the Volume CV input drops below 5 volts, the output is reduced.

**PAN INPUT:** A  $-2.5$  to  $2.5$  V control voltage applied to this jack will cause the output signal to pan from left to right.

## F. MODULATION BUSSES



Modulation is the heart of making interesting sounds with analog subtractive synthesis. The Voyager's two Modulation busses open up a world of modulation possibilities that were not available on the original Minimoog. The Mod Busses allow the user to select a variety of modulation sources, their destinations, addition shaping of the amount of modulation, and a maximum level. The Mod busses are labeled Mod Wheel and Pedal/On. The performance controls for these two busses are the Mod Wheel and the MOD1 input on the back panel. The MOD1 input can accept an expression pedal like the EP-1, and is used like the Mod wheel to fade in and out the desired modulation. With nothing plugged into the MOD1 input, the Amount control of the Pedal/On bus determines the strength of modulation.

Here's a block diagram of a Mod bus (figure 23):

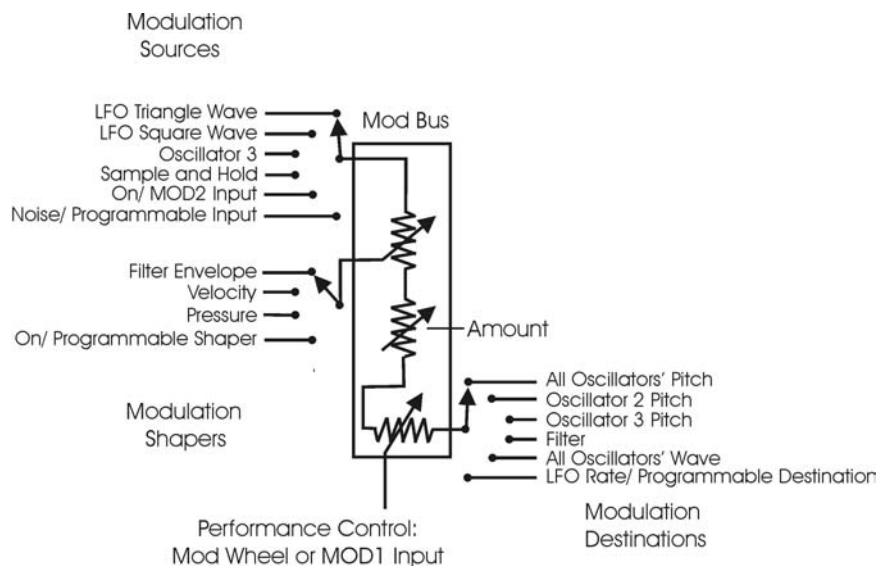

figure 23

There are three modifiers to the Amount of modulation: the Amount control, the Shaping CV, and the Mod Wheel or MOD1 input level. The Amount level is the final level control which sets how much both the Mod Wheel/ MOD1 Input and the shaping CV allow the mod source through to the mod destination.

To try out a simple modulation, set the LFO to about 6 Hz, the Source to triangle wave, the destination to Pitch, the shaping to on, and the amount to 5. The Mod Wheel can be used to fade in the modulation, which should sound something like vibrato.

This is a simple use of a mod bus. The flexibility of the two Modulation Busses offer a wealth of modulation possibilities which make the Voyager an incredible sound design tool.

### **SOURCE:**

Choosing a modulation source is done through a combination of the Mod Source Switch and the menus of the software. The Mod Source selector switch is a 6-position switch. The Front panel selections are:

- TRI: LFO Triangle Wave
- SQ: LFO Square Wave
- S+H: Sample and Hold output
- OSC. 3: Oscillator 3
- ON/MOD2: with nothing plugged into the MOD2 jack, this is a steady +5 V signal. The MOD2 input is for using external CVs as a Modulation source.
- NOISE/PGM: This is a programmable source for the mod bus with Noise as the default. The programmable Mod sources are set in the EDIT mode menu items MOD WHEEL PGM SOURCE or PEDAL PGM SOURCE.

### **SHAPING:**

The shaping is a way to dynamically change the amount that the Mod Source modulates the Mod Destination. Shaping occurs before the Amount control and before the Performance controls. The switch that selects this is a 4-position switch that is labeled:

- FILT. ENV.: This allows the filter envelope to shape the amount of Modulation before the Mod Wheel or MOD1 performance control.
- VELOCITY: This allows Keyboard Velocity to shape the amount of Modulation before the Mod Wheel or MOD1 performance control.
- PRESSURE: This allows Keyboard afterpressure to shape the amount of Modulation before the Mod Wheel or MOD1 performance control. The pressure signal that comes out of the keyboard is either on or off, thus pressure can be used as a switch that gives a boost to the amount of modulation.
- ON/PGM: This is a programmable shaping for the mod bus with ON as the default. The programmable Mod shaping is not implemented in Version 1.0 of the Software. The default, On, is active.

### **DESTINATION:**

A modulation destination is chosen in the same manner as the Mod source: a combination of the 6 position destination switch and the software menus. The Destination switch is labeled:

- PITCH: The Pitch of all three Oscillators
- OSC.2: The Pitch of Oscillator 2

- OSC.3: The Pitch of Oscillator 3
- FILTER: The Filters' Cutoff frequency
- WAVE: All 3 Oscillators waveform
- LFO/PGM: This is a programmable destination for the mod bus with LFO Rate as the default. The programmable Mod destination is set in the EDIT mode menu items MOD WHEEL PGM DEST or PEDAL PGM DEST.

#### **AMOUNT:**

The Amount control is used to set the maximum amount of modulation sent to the Modulation Destination. When the Amount control is set to 0, no modulation will pass through to the Modulation Destination. When the Amount is set to 10, The maximum amount of modulation is sent to the Destination when the Performance controller (Mod Wheel or MOD1 Input) is all the way up.

#### **MOD BUS PERFORMANCE CONTROLLERS: Mod Wheel and MOD1 Input**

The Mod Wheel and MOD1 Input are performance controllers for the Mod Wheel Mod Bus and the Pedal/On Mod Bus respectively. They are the final stage in determining the amount of modulation sent to the selected Destination. When at maximum, the modulation amount is determined by the Amount control. When off, the modulation amount is 0.

#### **MOD 1:**

The MOD1 input accepts an expression pedal or control voltage from 0 to 5 Volts. This is used as the performance control for the PEDAL/ON Mod Bus. With nothing plugged into this jack, the voltage here is 5 Volts. When the voltage is at 0, no modulation is sent to the PEDAL/ON Modulation Destination. When the Voltage at the MOD1 is at 5 Volts, the Modulation is sent to the Destination at the level set by the PEDAL/ON Amount control.

#### **MOD2:**

The MOD2 input is for applying an external modulation source into the MOD busses. The input accepts an Expression Pedal or a control voltage of -5 to +5. With nothing plugged into this jack, the voltage here is 5 Volts. When the SOURCE switch selects ON/ MOD2, the Voltage that is at this jack becomes the Modulation source.

## G. LFO/ SAMPLE AND HOLD



The Voyager has a dedicated LFO and SAMPLE and HOLD. The LFO produces triangle and square waves that oscillate from .2 to 50 Hz. There are triangle and square wave outputs that can be selected as Modulation sources in the Mod Busses. The Square wave is routed to the Sample and Hold trigger input, and the noise source is routed to the sample and hold input. For each cycle of the LFO, the voltage at the input of the sample and hold circuit is held until the next trigger event. Noise is a random signal, so the voltage that appears at the output of the sample and hold is a random voltage that changes in time with the LFO. If a plug is inserted into the sample and hold gate input on the back Panel, it will disconnect the LFO from triggering the sample and hold circuit. A gate signal or footswitch will trigger the sample and hold circuit. Similarly, a plug inserted into the Sample and Hold input Jack disconnects the noise from the S+H input. In this circumstance when the S+H circuit is triggered, the voltage at the tip of the plug is held at the output of the S+H circuit. In this way the user can get "staircase" modulation patterns (figure 24).

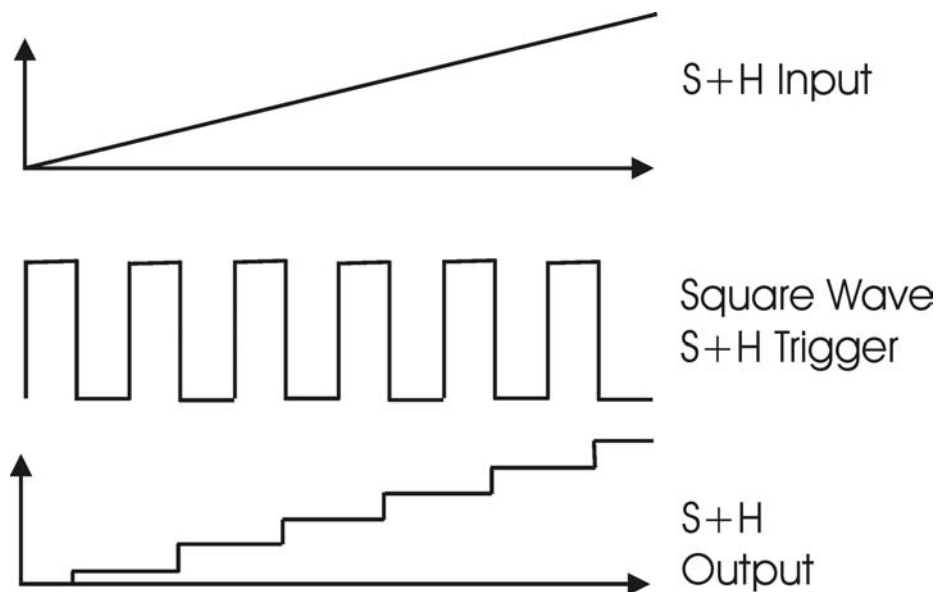

figure 24

**LFO RATE:**

The LFO Rate control sets the Rate of the dedicated LFO. The range of oscillation is .2 Hz to 50 Hz.

**LFO SYNC:**

The LFO Sync switch sets the trigger method for starting the LFO waveform.

OFF/SYNC: This setting allows the LFO to be free running, unless there is an input to the SYNC jack on the back panel. The SYNC jack accepts a +5 V Clock Signal that retriggers the LFO.

MIDI: Allows a MIDI clock signal to retrigger the LFO. MIDI Clock triggering the LFO is not implemented in Version 1.0

KB: Allows the LFO to be retriggered when a note on the keyboard is started.

ENV. GATE: Allows a gate input to the ENVELOPE GATE jack on the back panel to retrigger the LFO.

**LFO RATE INPUT:**

This jack accepts an expression pedal or control voltage from -5 to +5 Volts. A positive voltage here adds to the position of the LFO Rate control, a negative voltage here will subtract from the position of the LFO Rate control.

**LFO SYNC INPUT:**

This jack accepts a footswitch or +5 V Gate input. Closing the footswitch or applying a gate here will retrigger the LFO Waveform.

**SAMPLE AND HOLD INPUT:**

This jack accepts an expression pedal or control voltage from -5 to +5 Volts. The Voltage here is applied to the Sample and Hold Input.

**SAMPLE AND HOLD GATE INPUT:**

A +5 Gate signal will trigger the Sample and Hold Circuit.

## **H. KEYBOARD AND LEFT HAND CONTROL PANEL**

The Voyager has a 44 note keyboard (3 ½ octaves F to C), like the original minimoog. Unlike the original minimoog, the keyboard can produce velocity CVs, a pressure CV, and transmit MIDI note on messages. To the left of the keyboard is the Left Hand Controller Panel. It features the Pitch Bend and Mod Wheel controls and the glide and release switches.

**PITCH BEND WHEEL:** This control affects the pitch of all three oscillators.

**MOD WHEEL:** This control sets the amount of modulation that is sent to the Modulation destination of the Mod Wheel Mod bus.

**GLIDE:** This switch turns on and off the GLIDE circuit.

**RELEASE:** This switch is used to shorten the Release time of both the filter and Volume envelopes. You will notice that with very long release times, the release is shortened, but not off all the way.

## I. TOUCH SURFACE CONTROLLER

The touch surface controller is a real-time three-dimensional control surface. It can be used to impart complex gestures to the sound of the Voyager by touching it, moving a finger around on it or tapping it. A movement from left to right is the X-axis, up and down is the Y-axis, and the amount of area covered is the third control signal generated, called 'A'. The movements in the X and Y axes and the area covered on the Touch surface produce three separate control signals which can be routed to a number of the Voyager's parameters.

The control signals generated by the Touch Surface can be routed two ways:

- Destinations are programmed in a preset in EDIT Mode using the "Touch Surface Destinations" item. There are 32 possible destinations selectable for each axis; the setup of destinations can be saved in a Preset.
- The Touch Surface X and Y axes can be selected as Programmable Mod Buss Sources using the Edit function "PGM Mod Whl Source", or "PGM Pedal Source"

Details on programming the touch surface destinations are contained in the section covering EDIT Mode.

With the touch surface controller there is no right and wrong way to use it. Experimentation is the key. It is an exciting way to explore synthesis performance – with 3 control signals generated from a single finger in contact with the touch surface, it is like turning three knobs at the same time – giving you the capability to "morph" sounds in a variety of ways.

## J. THE BACK PANEL

The Back Panel is loaded with Jacks. In addition to the Audio Outputs, there are a multitude of CV and gate inputs, the MIDI connectors, a BNC outlet for a gooseneck lamp, the accessory port, and the power connector.

**POWER CONNECTOR:** This is a standard AC power inlet, Use only a power cord designed to mate with this receptacle. The Voyager power supply is designed to work with power inputs of 100-240 VAC.

**DANGER – Do not alter this connector in any way. Doing so can result in the risk of shock, injury or death.**

**Be familiar with the safety instructions printed at the beginning of this manual. If the connector should be damaged, refer servicing to qualified personnel only.**

**MIDI CONNECTORS:** These are connectors for MIDI in, out and thru.

**BNC LAMP CONNECTOR:** This is a 12 VDC BNC outlet for a gooseneck lamp.

**CV/EXPRESSION and GATE/FOOTSWITCH INPUTS:** The CV/ Expression inputs are color coded with red nut. These jacks accept an input from an expression pedal such as the EP-1, or a CV from –5 to +5 Volts. The Gate/Footswitch Inputs are color coded with blue nuts. All Gate inputs accept footswitches *except* the Sample and Hold Gate Input. It accepts only a +5 Volt Gate Signal.

**ACCESSORY PORT:** This is designed for accessories from Moog Music – The vx-351 Voyager CV Expander It contains the output of the analog gates and CVs from the Voyager. With the VX-351, the Voyager becomes more like a modular synth. Appendix E contains the user's manual for the VX-351.

## K. THE USER INTERFACE/ VOYAGER SOFTWARE VERSION 2.5

### 1. The Interface

The interface for the minimoog Voyager's software functions is in the center of the instrument (figure 25).

(figure 25)

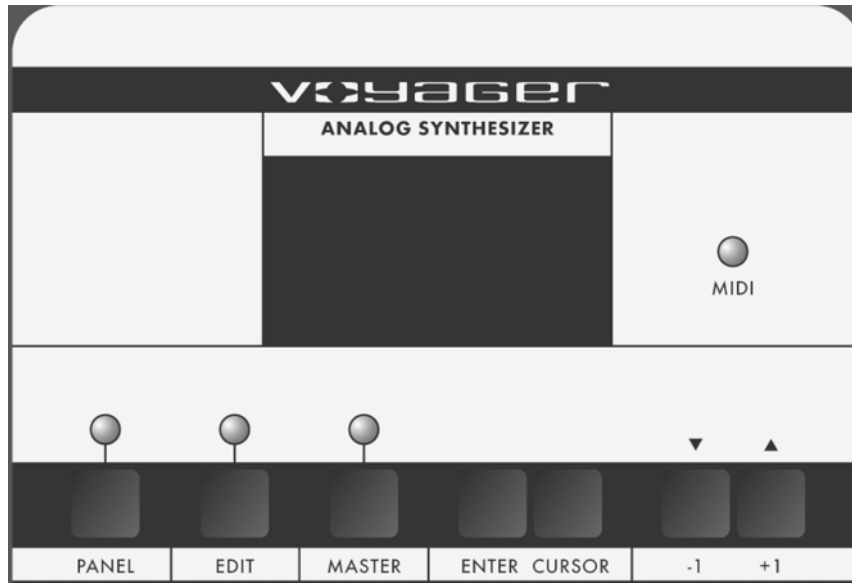

The display is a LCD screen in the center. When the unit is first powered on, the screen will read the message:



The message will stay on the screen for approximately 5 seconds, then the screen will display the current active preset. Note that the LED above the button labeled "PANEL" is lit. The sound produced will be the last sound used before the Voyager was powered down previously.

There are three operating modes for the Voyager:

- MASTER: Used for accessing Global settings for the Voyager, and data send and receive functions.
  - EDIT: Used for editing parameters of a preset not accessed through the front panel. Naming and saving presets is done in EDIT mode.
  - PANEL: Used for accessing the Voyager's presets and performance functions.
- The Voyager contains 128 presets.

## 2. MASTER Mode

MASTER mode accesses the global settings for the Voyager and the routines for sending and receiving data.

To enter MASTER mode, press the MASTER button. The following is the Master Menu:

- 1.1 LCD Contrast
- 1.2 MIDI Local Keyb.
- 1.3 MIDI Merge Func.
- 1.4 MIDI Prg. Change
- 2.1 MIDI In Channel
- 2.2 MIDI Out Channel
- 2.3 MIDI In ON/OFF
- 2.4 MIDI Out ON/OFF
- 3.1 Send Panel Sound
- 3.2 Send All Presets
- 3.3 Receive Presets
- 3.4 SysEx Device ID
- 4.1 Transpose In/Out
- 4.2 MIDI Key Order
- 4.3 Velocity Curve
- 4.4 Copyright Info
- 5.1 Software Version
- 5.2 Send System ROM
- 5.3 Send Boot System
- 5.4 Receive Update

The +1/ -1 buttons scroll through the list. The list will wrap around when you scroll past the end. When a line is highlighted, it can be selected by pressing the ENTER button. Once a line is selected, the screen displays that option.

Press the MASTER, CURSOR or ENTER button to return to the MASTER Menu.

### 1.1 LCD CONTRAST

When this is selected, use the +1/ -1 buttons to change the LCD contrast. Different angles of the front panel may require different contrast settings for comfortable viewing of the display.

### 1.2 MIDI LOCAL KYBD.

Local Control On/Off for the keyboard. This turns off the keyboard's internal connection to the Voyager. This is used in the case you do NOT want the keyboard to trigger the Voyager's envelopes or change the pitch of the oscillators. This is commonly used when triggering the Voyager from a sequencer – and prevents accidental interference with the notes being played by the sequencer. This does not disable the functions of the front panel controls.

### 1.3 MIDI MERGE FUNC.

Turns MIDI merge On/Off. With Merge ON, a MIDI message appearing at the Voyager's MIDI in is sent to the Voyager's MIDI out and is combined with the Voyager's

internally generated MIDI messages. When sequencing, this function should be turned off to prevent "double triggering" caused by a MIDI loop.

#### 1.4 MIDI PRG. CHANGE

Program Change Receive On/Off. This enables or disables the Voyager's reception of MIDI program changes. When this is off, only the +/- 1 buttons change the Voyager's presets.

#### 2.1 MIDI IN CHANNEL

When this is selected, use the +1/ -1 buttons to select the MIDI Channel that the Voyager recognizes. The Voyager only responds to one channel at a time. The choices are 1-16.

#### 2.2 MIDI OUT CHANNEL

When this is selected, use the +1/ -1 buttons to select the MIDI Channel that the Voyager uses to send Data. The Voyager sends MIDI on one channel at a time. The choices are 1-16.

#### 2.3 MIDI IN ON/OFF

This turns On or Off the MIDI Input. To use, select MIDI In On/Off and press ENTER. The screen will prompt: "Switch ON the MIDI In function? Yes/No". Use CURSOR to select "Yes" to turn on the MIDI input and "No" to turn Off the MIDI input, then Press ENTER.

#### 2.4 MIDI OUT ON/OFF

This turns On or Off the MIDI Output. To use, select MIDI Out On/Off and press ENTER. The screen will prompt: "Switch ON the MIDI Out function? Yes/No". Use CURSOR to select "Yes" to turn on the MIDI Output and "No" to turn Off the MIDI Output, then Press ENTER.

#### 3.1 SEND PANEL SOUND

For outputting single presets as a SysEx file. This function allows the export of a single preset from the Voyager's bank of presets. The Voyager also has the ability to import a single preset in PANEL mode. This allows the Voyager user to build up custom preset banks. This requires another Voyager, or a computer with a MIDI interface and a program that can accept a manual Sysex dump. You must enable the device that is to receive the Sysex data. Once the remote device is enabled, press ENTER to start the data transfer.

#### 3.2 SEND ALL PRESETS

This is a utility to send Sysex (System Exclusive) data for archiving the bank of 128 presets in the Voyager's memory. This requires another Voyager, or a computer with a MIDI interface and a program that can accept a manual Sysex dump. You must enable the device that is to receive the Sysex data. Once the remote device is enabled, press ENTER to start the data transfer.

#### 3.3 RECEIVE PRESETS

This is a utility to import Sysex data for a bank of Voyager presets. This requires another Voyager, or a computer with a MIDI interface, a program that can send a Sysex bank, and a bank of Voyager presets. The Voyager must be enabled to receive the presets. When entered, the screen will prompt the user: "Sysex enabled". At this time, a Sysex transfer from a remote device can be started. To disable the ability to receive Sysex, press the -1 button, or press ENTER to return to the MASTER menu. This

utility will replace any presets that are in memory, so be sure to back up any presets you want to save before going through this process.

### 3.4 PROGRAMMABLE SYSEX DEVICE ID

This function can be used in a situation where more than one Voyagers are in a setup. By Changing the SysEx Device ID, when a Preset Bank is sent, the Device ID byte in that SysEx message matches the Device ID set in that Voyager. When a SysEx data stream is sent to the Voyagers, only the Voyagers that have matching Device IDs receive the SysEx messages. This way, when more than one Voyagers are used, and each one has a different SysEx Device ID, Presets or Preset banks can be sent to an individual Voyager in that setup. To use this feature, select "SysEx Device ID" and press ENTER. The screen will prompt: "System Exclusive ID Number → 1". Use the + or – buttons to select a number between 1 and 128.

### 4.1 TRANSCOPE IN/OUT

The Transpose In/Out function can be used independently for MIDI Notes transmitted and received. To use this feature, select "Transpose In/Out". The screen will prompt: "Keyboard Transpose Semitone(s) \_\_\_; MIDI Key Transpose Semitone(s) \_\_\_". Keyboard Transpose Semitones refers to the number of semitones that the MIDI notes generated by the Keyboard (MIDI out) are transposed: up to 24 up or 48 down. MIDI Key Transpose Semitones is the number of semitones that the MIDI notes received by the Voyager are transposed: maximum 48 up and 48 down. The CURSOR button is used to move between the Keyboard and MIDI key Transpose values. Use the +/- buttons to select the number of semitones you wish to transpose up or down. The values set here are not remembered on power down – they must be set each time the Voyager is powered on if this function is used.

If the Voyager is controlling a device such as a drum machine or sampler, where drum sounds are mapped to low MIDI Note number values, then Keyboard transpose can be used to lower the values of the Voyager's MIDI Note On values. However, if you do not want this to affect the pitch of the Voyager, then do the following things: first, make sure the Voyager's MIDI Merge function is Off. Second, Connect the Voyager's MIDI out to the drum machine or sampler. Third, if you are recording sequences including the Voyager, make sure the drum Machine or sampler's MIDI input is echoed to the output, connect the MIDI out to the Voyager's MIDI In. Fourth, in the Voyagers Master Mode, turn Local Keyboard control OFF, and then go to the Transpose In/Out function. Finally, lower the Keyboard Transpose Semitone Value – 24 semitones, then set the MIDI Key Transpose Semitone value to +24 Semitones. The result is that the Voyager can trigger MIDI notes 2 octaves lower, yet sound the same.

### 4.2 MIDI KEY ORDER

The MIDI Key Order function allows multiple Voyagers to function together as a polyphonic synth. Up to 16 Voyagers can be Linked together to create a 16 voice synth. The Value of the MIDI Key Order Number assigns the Voyager to one of 16 voices on the MIDI input. To use this function, select "MIDI Key Order" and press ENTER. The screen will prompt: "MIDI In Key Order is not active" Use the +/- Buttons to select if this is not active, or 1-16, then confirm by pressing ENTER. If you are using a single Voyager – make sure this feature is not active, especially if using with a MIDI sequencer.

### 4.3 VELOCITY CURVE

This adjusts the Velocity values of the Voyager's MIDI Note On output to one of three different curves: Soft, Normal, or Hard. Soft increases the average velocity output, so playing with a lighter touch creates a higher velocity value. Normal is the unprocessed

velocity output from the keyboard. Hard requires a harder touch to output higher velocity values.

#### 4.4 COPYRIGHT INFO/ FACTORY SETUP MENU

Copyright Info, shows the copyright dates, as well as the author of this software, Rudi Linhard (Thanks, Rudi!). This is the entry page to the Factory Setup menu – simply press the +1 button to see the Factory Setup Menu. These functions are used for initializing parameters in the Voyager's Preset bank. While in the Factory Setup Menu, press CURSOR, or MASTER to return to the Master Mode Menu. The Factory Setup Menu has two pages of functions – the each function has a page number and a line number. Here they are:

##### 1.1 Factory Sounds

The Factory Sounds function is to restore the Voyager to its default factory state. Performing this function will wipe out any presets in memory and replace them with the standard Voyager Performer Edition Preset Bank – programmed by Zon Vern Pyles, so don't do this unless you are sure you want to. Select "Factory Sounds" and press ENTER. The screen will prompt: "Reload the Factory Preset Sounds and Default Functions? Yes/No". To restore the Voyager's factory presets select "Yes" and press ENTER. To escape without restoring the Factory presets, select "No" and press ENTER.

##### 1.2 Master Volume

The Master Volume function is used to invert the stored Master Volume values of the Voyager's Presets. This can be useful if you have a bank that has all the Master Volume parameters stored at 0, by performing this function, the Volume values will be changed to the Maximum Volume.

##### 1.3 T.S. XYAG Dest.

The T.S. XYAG Destination function is used to restore the default parameters of the Touch Surface destinations, MIDI CC off/ or number, Direction of control, and amounts for the X,Y, Area axes as well as the Touch Surface Gate. The Default values are:

X= Filter Cutoff, MIDI CC = Off, Direction= Normal, TS-X amount 50%  
Y = Filter Spacing, MIDI CC = Off, Direction= Normal, TS-X amount 50%  
A = Filter Resonance, MIDI CC = Off, Direction= Normal, TS-X amount 50%  
Gate = No switch, MIDI CC = 88, Polarity = Normal

To initialize the Voyager's Touch Surface parameters, select the function "T.S. XYAG Dest." and press ENTER. The screen will prompt: "Reset the Touch Surface XYA & Gate Setup of all Preset Sounds? Yes/No" Select Yes and press ENTER. Press CURSOR to get back to the Master Mode menu.

##### 1.4 Shaping 1&2

The "Shaping 1&2" function restores the default settings for the Programmable Mod Buss Shaping Sources. The defaults for both sources are: "fixed value, value = 0". To restore the default settings for Shaping 1&2 sources, select the function "Shaping 1&2" and press ENTER. The screen will prompt: "Reset Shaping 1&2 Functions of all Preset Sounds? Yes/No". Select Yes and press ENTER.

##### 2.1 Clock Divider

The "Clock Divider" function restores the default settings for the clock divider parameter stored in the presets. The default value is "24", which is an 8<sup>th</sup> note (half a beat). To restore the clock divider values to their defaults, select the function "Clock Divider" and press ENTER. The screen will prompt: "Reset the Clock Divider Values of all Preset Sounds? Yes/No" Select Yes and press ENTER.

## 2.2 Pot Mapping

The "Pot Mapping" function restores the default settings for the Pot Mapping parameters stored in the presets. Select the function "Pot Mapping" and press ENTER. The screen will prompt: "Reset the Pot Mapping function of all Preset Sounds? Yes/No". Select Yes and Press ENTER.

## 2.3 Env Gates F/A

The "Env Gates F/A" function restores the default settings for the Filter and Amplitude Envelope Gates parameters stored in the presets. The default is "ENV Gate Input". To restore the default Envelope gate settings, select the function "Env. Gates F/A" and press ENTER. The Screen will prompt: "Reset the Env Gates Filter/Amplitude for all Preset Sounds? Yes/No" Select Yes and press ENTER.

## 2.4 Power-On Screen

The "Power-On Screen" functions allows the user to select the original Voyager power on logo, or the new version 2.5 power on logo. There is no difference in performance, but the new Power-On screen displays the Moog logo and the software version. To change the appearance of the Power on screen, select "Power-On Screen" and press ENTER. The screen prompts: " Get the old Power-ON-Logo on the display screen? Yes/No". Select "No" and press ENTER.

## 5.1 SOFTWARE VERSION

Displays the current System ROM version and date of the release.

## 5.2 SEND SYSTEM ROM

This utility allows you to back up your operating system via Sysex data. This screen displays the prompt: "Press Enter to send Prog Data". The boot software version will be displayed on the bottom line. Before you press enter, be sure the remote device is enabled to receive the data. Pressing ENTER will start the export. We recommend backing up the operating system before upgrading to a new version of software.

## 5.3 SEND BOOT SYSTEM

This utility allows you to back up your boot software via Sysex data. This screen displays the prompt: "Press Enter to send Boot Data". The boot software version will be displayed on the bottom line. Before you press enter, be sure the remote device is enabled to receive the data. Pressing ENTER will start the export.

## 5.4 RECEIVE UPDATE

This utility is used to upgrade the system software. Updates will be available from time to time on our website, [www.moogmusic.com](http://www.moogmusic.com) in Minimoog Voyager section, entitled "software". Instructions for upgrading the software are provided with the files – you must follow these instructions! To take advantage of this feature requires the following:

- A computer with internet access and MIDI interface.

- MIDI Software capable of sending a generic Sysex bank file (.syx) or Standard MIDI file (.mid)

Many sequencers are capable of opening Sysex files and sending Sysex data. If you do not own one of these, check out "MIDI-OX", a MIDI utility software for PC available online at [www.midiox.com](http://www.midiox.com). For Mac, there is a program called "Sysex" that provides the same function. Many sequencers can be used to import the Standard MIDI file versions (.mid) of the software. be sure you understand fully the settings in your sequencer that may affect the transmission of Sysex data. *It is beyond the scope of this manual to explain how to import or open files containing SysEx data in the many different MIDI programs available – it is the user's responsibility to know and be familiar with this aspect of the upgrade! If you have questions about your software's capabilities to send large SysEx messages, contact your software vendor.*

If you do not own a computer, special arrangements will need to be made for software upgrades. Please contact [techsupport@moogmusic.com](mailto:techsupport@moogmusic.com).

When entering the RECEIVE UPDATE screen, the screen will ask if you are sure you want to upgrade the software. Selecting YES will initialize the memory and enable the Voyager to receive the Sysex data containing the new Operating System software. There is no danger of losing the current Software if your MIDI software is not properly configured. The new operating system does not become active until the Sysex data transfer is confirmed as successful.

### 3. EDIT Mode

EDIT Mode is used to determine parameters of a preset not accessible through the front panel and to name and save presets. EDIT mode is entered by pressing the EDIT button. When this is done, a list appears that displays the different options. Using the +1 or -1 buttons moves the cursor to highlight a new line. There are four items per page, and 6 pages. The page number and item number are displayed in the EDIT menu. The Options in EDIT mode are:

- 1.1 Compare to Preset
- 1.2 Recall last Sound
- 1.3 Real Panel Contr.
- 1.4 Pitch Bend Amt.
- 2.1 PGM M-Whl. Source
- 2.2 PGM M-Whl. Dest.
- 2.3 PGM Pedal Source
- 2.4 PGM Pedal Dest.
- 3.1 PGM Shaping 1 SRC
- 3.2 PGM Shaping 2 SRC
- 3.3 Keyboard Modes
- 3.4 Trigger Modes
- 4.1 Fil. A Pole Sel.
- 4.2 Fil. B Pole Sel.
- 4.3 Fil. ENV Gate SRC
- 4.4 Amp. ENV Gate SRC
- 5.1 T.S. Destinations
- 5.2 T.S. Mem. Mod Bus
- 5.3 T.S. Mem Global
- 5.4 Pot Mapping S/D
- 6.1 LFO Clock Divider
- 6.2 Init. Parameters
- 6.3 Preset Name
- 6.4 Save Preset

#### 1.1 COMPARE TO PRESET

The "COMPARE TO PRESET" function in EDIT mode can be used to compare the current Panel sound to any other preset in the Voyager's Preset bank. Applications for this include comparing an edited version of a sound to its original version in memory, or to find a preset location that you do not use, where you can store your current Panel Sound. To use this function, select "Compare to Preset" and press ENTER. The screen prompts: "Cursor toggles between Panel sound and Preset. Panel ← → Preset. Pre-set # 001". Note that the sound that is currently heard when the Voyager is played is highlighted. The CURSOR button is used to change between the panel sound, and a preset. The Preset number can be changed with the +/- buttons.

#### 1.2 RECALL LAST SOUND:

RECALL LAST SOUND is a function that returns to a previously edited version of a sound. This is used in conjunction with PANEL Mode. If you are in PANEL Mode and make changes to a preset and then press ENTER, the sound reverts to the original saved settings. If you want to get back your tweaks, Press the EDIT button to enter EDIT mode –

RECALL will be highlighted. Press ENTER, and the display will prompt "Recall the last edited sound? Yes/No". Use the cursor button to select Yes and press ENTER. You will now hear the changes you made to the preset. At this point if you want to keep those changes, you can save the preset. RECALL can also be used to return to a preset sound after the parameters are initialized (INIT. PARAMETERS or REAL PANEL CONTROL see below).

### 1.3 REAL PANEL CONTR.:

REAL PANEL CONTROL is a function that enables the operation of the Voyager from the front panel. To use this function, enter EDIT MODE by pressing the EDIT button. Press the +1 key to highlight REAL PANEL CONT. and press ENTER. The screen prompts: "Load the actual Panel Parameters Yes/No?" Use the CURSOR button to select Yes and press ENTER. The sound produced when the keyboard is played is now determined by the settings of the front panel controls.

### 1.4 PITCH BEND AMT.:

PITCH BEND AMOUNT allows the user to set a pitch bend range for each preset. Highlight the PITCH BEND AMT. function in the EDIT Menu and press ENTER. Use the +/- 1 buttons to select the desired range for the pitch bend wheel.

The options are:

Off

+/- 2 Semitones

+/- Minor Third

+/- Major Third

+/- Fourth (default)

+/- Fifth

+/- 1 Octave

+/- 1 Octave & 5<sup>th</sup>

+/- 2 Octaves

+/- 2 Octaves & 5<sup>th</sup>

Pre. -Value

Pre. -Value is a user defined Pitch Bend Amount. The value of this is set with the External Audio Input control. Simply push the Pitch Bend Wheel forward and listen to the pitch change as you rotate the External Audio Input control – stop when the desired interval between full pitch bend and no pitch bend is reached.

### 2.1 PGM M-WHL SOURCE

PROGRAMMABLE MOD WHEEL SOURCE is a function that allows the user to program 1 of 8 additional modulation sources to be used when the SOURCE switch for the Mod Wheel Mod Bus is set to NOISE/PGM. Enter EDIT mode, and use the +1 button to highlight PGM M-WHL SOURCE. Press ENTER and the following Mod Sources appear:

Noise (default)

Filter ENV

Amplitude ENV

Smoothed Sample and Hold

Oscillator 1

Oscillator 2

Touch Surface X

Touch Surface Y

### 2.2 PGM M-WHL DEST.

PROGRAMMABLE MOD WHEEL DESTINATION is a function that allows the user to program 1 of 8 additional modulation destinations to be used when the DESTINATION switch for the Mod Wheel Mod Bus is set to LFO RATE/PGM. Enter EDIT mode, and use the +1 button to highlight PGM M-WHL DEST. Press ENTER and the following Mod Destinations appear:

- LFO Rate (default)
- Filter Resonance
- Filter Spacing
- Panorama
- Osc. 1 Level
- Osc. 2 Level
- Osc. 3 Level
- Noise Level

### 2.3 PGM PEDAL SOURCE

PROGRAMMABLE PEDAL/ON SOURCE is a function that allows the user to program 1 of 8 additional modulation sources to be used when the SOURCE switch for the Pedal/On Mod Bus is set to NOISE/PGM. Enter EDIT mode, and use the +1 button to highlight PGM PEDAL SOURCE. Press ENTER and the following Mod Sources appear:

- Noise (default)
- Filter ENV
- Amplitude ENV
- Smoothed Sample and Hold
- Oscillator 1
- Oscillator 2
- Touch Surface X
- Touch Surface Y

### 2.4 PGM PEDAL DEST.

PROGRAMMABLE PEDAL/ON DESTINATION is a function that allows the user to program 1 of 8 additional modulation destinations to be used when the DESTINATION switch for the Pedal/On Mod Bus is set to LFO RATE/PGM. Enter EDIT mode, and use the +1 button to highlight PGM PEDAL DEST. Press ENTER and the following Mod Destinations appear:

- LFO Rate (default)
- Filter Resonance
- Filter Spacing
- Panorama
- Osc. 1 Level
- Osc. 2 Level
- Osc. 3 Level
- Noise Level

### 3.1 PROGRAMMABLE SHAPING SOURCE 1

### 3.2 PROGRAMMABLE SHAPING SOURCE 2

On both Mod Busses, the Shaping switches point to "On/PGM" in their full Clockwise position. "PGM" stands for the programmable shaping sources. There are two programmable shaping sources – both are combined by the software and shared by both Mod Buss Shaping switches. When either of the Shaping switches are in the On/PGM position, the Programmable Shaping values stored in memory are applied to Shape the Mod Buss source. Shaping is like an additional level control for modulation amount – in the case of a Shaping signal like velocity, the higher the velocity, the more

the Mod Source is let through to the Destination. The Programmable Shapers also allow an offset value to be applied, added to the Shaper itself.

Using the programmable Shapers is useful for creating presets that respond in complex ways – for instance – you could assign BOTH key pitch and velocity as your programmable shaping sources. In this case, the higher and the harder you play, more modulation source is passed to modulate the destination. Many of the Shaping sources are front panel rotary controls. A possible application using a front panel control as a shaping source is having the Filter cutoff also control the Modulation amount.

Programmable shapers can make for some highly interesting and interactive presets. The Possible shaping signals for both Programmable shapers 1 and 2 are:

- Fixed Value
- Pitch Bend Wheel
- Modulation Wheel
- Velocity Release
- Pressure (AT)
- Keyboard CV
- Touch Surface X
- Touch Surface Y
- Touch Surface A
- Modulation Bus 1
- Modulation Bus 2
- LFO Rate
- Glide Rate
- Mod.Wheel Amount
- Pedal Amount
- Osc. 1 Octave
- Osc. 1 Waveform
- Osc. 2 Frequency
- Osc. 2 Octave
- Osc. 2 Waveform
- Osc. 3 Frequency
- Osc. 3 Octave
- Osc. 3 Waveform
- Ext. Audio Level
- Osc. 1 Level
- Osc. 2 Level
- Osc. 3 Level
- Noise Level
- Filter Cutoff
- Filter Spacing
- Filter Resonance
- Filter KB Control Amount
- Filter Attack
- Filter Decay
- Filter Sustain
- Filter Release
- Filter Envelope Amount
- Volume Attack
- Volume Decay
- Volume Sustain
- Volume Release
- Master Volume

- Headphone Volume

The Fixed Value can be used by itself or added to one of the Shaping sources. It has a course adjustment, called "High" and a Fine adjustment, called "Low". Both the High and Low values are adjustable from -64 to +64. The CURSOR button moves the cursor between the Shaping Source, the High fixed value and the low fixed value.

### 3.3 KEYBOARD MODES

KEYBOARD MODES allows the user to select 1 of 4 types of keyboard priority for a preset. Keyboard priority for a monophonic instrument determines what happens when more than one key is depressed. Enter EDIT mode and use the +1 or -1 button to highlight KEYBOARD MODES. Press ENTER and the current Keyboard Mode appears. Use the +/-1 buttons to choose from one of the following options.

Lower Key (the lowest key pressed sounds)

Higher Key (the highest key pressed sounds)

Last Key (the most recent key pressed sounds)

1 Key Only (the first key pressed sounds)

### 3.4 TRIGGER MODES

TRIGGER MODES allows the user to select how the envelopes are triggered when more than one key is pressed on the keyboard. Enter EDIT mode and use the +1 or -1 button to highlight TRIGGER MODES. Press ENTER – the screen will display the current Trigger Mode. The +/- 1 button chooses a different option. The choices are:  
Single Trigger (legato, envelopes aren't retriggered until keys are fully released)  
Multi Trigger (each time a new note sounds, the envelopes are triggered)

### 4.1 FIL. A POLE SEL.

This allows the configuration of the cutoff slope of Filter A. Filter A is the Filter that is controlled only by the cutoff control. In Dual lowpass it is the RIGHT output. In Highpass/Lowpass, it is the Lowpass filter. Use the +/-1 buttons to select 1, 2, 3, or 4 poles. A pole = 6dB/ octave cutoff slope – as the poles increase, so does the cutoff slope of the filter. a 1 pole filter has a 6 dB/ octave cutoff slope (when it's a lowpass filter you hear it as very bright) and a 4 pole filter has a 24 dB/ octave cutoff slope (when it's a lowpass filter you hear it as smooth, dark, yet warm).

### 4.2 FIL. B POLE SEL.

This allows the configuration of the cutoff slope of Filter B. Filter B is the Filter that is controlled by the Cutoff control and the Spacing control. In Dual lowpass it is the Left output (using both outputs). In Highpass/Lowpass, it is the Highpass filter. Use the +/-1 buttons to select 1, 2, 3, or 4 poles.

### 4.3 FILTER ENVELOPE GATE SOURCE

### 4.4 VOLUME ENVELOPE GATE SOURCE

With these two functions, gate sources other than the keyboard and the External Gate Input jack can be programmed to trigger the Voyager's two Envelope Generators when the Envelope Gate switch is in the On/External Position. Possibilities include:

- Envelope Gate Input (default – this is "On" with nothing plugged into this jack)
- Touch Gate (The gate signal from the touch surface)
- S&H Gate (This is the LFO square wave with nothing plugged into the S&H Gate jack)
- MIDI Clock
- Keyboard Gate
- Gate is ON

- Gate is OFF

### 5.1 T.S. DESTINATION

Touch Surface Destination. Highlighting this item and pressing ENTER accesses a menu that shows the different outputs of the Touch surface: X, Y, A, Gate. The screen looks like this:

```
Touch Surface X
Touch Surface Y
Touch Surface A
Touch Surface Gate
```

Use the +/- 1 button and selecting an output, then press ENTER. The display shows something like this:

```
Dest: Fil Cutoff
MIDI Ctrl. No. 19
Direction: Normal
TS-X Amount: 100%
```

The parameters for each touch surface axis are: touch surface destination, the MIDI CC being transmitted, the direction of control, and the amount (for X,Y, and A only). To get back to the Touch Surface menu, press ENTER. To return to the Edit Menu then press CURSOR or EDIT.

DEST.: Voyager users can choose one of 32 destinations for the Voyager's touch surface outputs X, Y and A, and 14 destinations are available for the touch surface gate. Here is a list of the destinations:

X, Y, and A

- LFO rate
- glide rate
- mod wheel mod bus amount
- volume
- pedal/on mod bus amount
- osc 1 waveform
- osc 2 frequency
- osc 2 waveform
- osc 3 frequency
- osc 3 waveform
- external audio in level
- osc 1 level
- osc 2 level
- osc 3 level
- noise level
- filter cutoff
- filter spacing
- filter resonance
- filter KB amount
- filter attack
- filter decay
- filter sustain
- filter release
- filter envelope amount

- volume attack
- volume decay
- volume sustain
- volume release
- key cv (pitch of all 3 oscillators across range of keyboard)
- osc 1 octave (pitch of single oscillator across range of keyboard)
- osc 2 octave (pitch of single oscillator across range of keyboard)
- osc 3 octave (pitch of single oscillator across range of keyboard)

#### T.S GATE:

- No Switch (default)
- Glide Switch
- Release Switch
- Osc. 1 → 2 Sync switch
- Osc. 3 → 1 FM switch
- Osc. 3 KB Control switch
- Osc. 3 Frequency Range switch
- External Audio On/Off switch
- Osc. 1 On/Off switch
- Osc. 2 On/Off switch
- Osc. 3 On/Off switch
- Noise On/Off switch
- Filter Mode switch
- Envelope Gate switch.

#### MIDI CTRL NO.

The Touch Surface can transmit user-selected MIDI CC Messages. For each of the X, Y and A axes, the Touch Surface can be set to transmit MIDI CCs 1-31, or it can transmit no MIDI information (off). The T.S. Gate can transmit MIDI CCs 64-127, values 0 (off) and 64 (on). If you are using the Voyager with a sequencer, then you'll want to transmit the CC numbers that corresponds to the Touch Surface Destinations. If you are using the Touch surface to control other MIDI devices, then you can choose the MIDI CC numbers appropriate to the parameters you wish to control in that device.

**DIRECTION:** normal or inverted – this selects a direction for the touch surface axes to modulate the destination.

For the X-axis, Normal means moving from *left to right* increases the destination's value, inverted means *right to left* increases the destination's value. For the Y-axis, normal means moving from *bottom to top* increases the destination's value, inverted means *top to bottom* increases the destination's value.

For the A (area) axis, normal means changing the area covered from *small to large* increases the destination's value, inverted means *large to small* increases the destination's value.

For the Gate, Normal means the Gate signal turns a switch ON (Note: This turns 3 KB Cont OFF). When the Gate is OFF (No contact w/ the Touch Surface), the switch is OFF. Inverse means a Gate Signal from the Touch surface turns the destination switch off, and when the Gate is OFF, the Switch is ON.

**AMOUNT:** OFF, 50%, or 100%. This parameter sets the amount of touch surface modulation of it's destination. Each axis can be set independently. OFF means

that axis does not modulate the destination. 50% means that the amount of the touch surface output adds 50% of the total range of that control to its present value. For example, if the Filter cutoff is the destination of touch surface x, the amount is set to 50%, and the Cutoff knob is fully counter clockwise, the maximum X value (all the way to the right) would make a change in the filter cutoff equal to turning the Cutoff knob to the mid-position. When the amount is set to 100%, the touch surface output equals the full range of the destination's control.

## 5.2 T. S. MEMORY MOD BUSS

TOUCH SURFACE MEMORY is for allowing the last known X and Y parameters of the touch surface to be held in memory after contact is no longer made with the touch surface. This is for the X and Y signals used as the programmable Sources in the MOD BUSSES. When this function is off, the X and Y values return to zero after contact with the touch surface is no longer made.

## 5.3 T. S. MEMORY GLOBAL

This adds memory to the direct destinations of Touch surface X and Y. When the user's finger is removed from the touch surface, the last X and Y values are remembered until the next time contact is made with the touch surface.

## 5.4 POT MAPPING SOURCE/DESTINATION

Pot Mapping is a new feature in Version 2.5 software that allows up to 4 different modulation routings different than the Mod Busses. In the Edit Menu, select Pot Mapping and press ENTER. The Pot Mapping Menu appears, showing Source and Destination Maps 1-4. Select a map and press ENTER. The screen now shows a Source (SRC), a Destination (Dest.), a Direction, and Amount. The CURSOR Button moves between the different parameters, and the +/- 1 buttons select the values. The available Pot Mapping Sources are:

Performance Controls:

- Pitch Bend
- Mod. Wheel (Default Source for SRC & DEST Map 3)
- Pressure
- Velocity Attack (Note On Velocity – Default Source for SRC & DEST Map 1)
- Velocity Release (Note Off Velocity)
- Foot Pedal 1 (Mod 1 Input – acts like Mod Wheel for Pedal/On Mod Buss, on if nothing is plugged into jack – Default Source for SRC & DEST Map 4)
- Foot Pedal 2 (Mod 2 Input – The On/Mod 2 Source of the Mod Busses, On if nothing is plugged in to this jack)
- Key Pitch – (CV from Keyboard – Default Source for SRC & DEST Map 2)

Front Panel Controls:

- LFO Rate
- Glide Rate
- Mod Wheel Amount
- Pedal Amount
- Osc. 1 Octave
- Osc. 1 Wave
- Osc. 2 Frequency
- Osc. 2 Octave
- Osc. 2 Waveform
- Osc. 3 Frequency

- Osc. 3 Octave
- Osc. 3 Waveform
- Ext. Audio Level
- Osc. 1 Level
- Osc. 2 Level
- Osc. 3 Level
- Noise Level
- Filter Cutoff
- Filter Spacing
- Filter Resonance
- Filter KB Control Amount
- Filter Attack
- Filter Decay
- Filter Sustain
- Filter Release
- Filter Envelope Amount
- Volume Attack
- Volume Decay
- Volume Sustain
- Volume Release
- Master Volume
- Headphone Volume

Available Pot Mapping Destinations are:

- Pitch Bend
- Mod. Wheel
- Pressure
- Velocity Attack (Note On Velocity)
- Velocity Release (Note Off Velocity)
- Foot Pedal 1 (Mod 1 Input – acts like Mod Wheel for Pedal/On Mod)
- Foot Pedal 2 (Mod 2 Input – The On/Mod 2 Source of the Mod Busses)
- Key Pitch – (CV from Keyboard)
- LFO Rate
- Glide Rate
- Mod Wheel Amount
- Pedal Amount
- Osc. 1 Octave
- Osc. 1 Wave
- Osc. 2 Frequency
- Osc. 2 Octave
- Osc. 2 Waveform
- Osc. 3 Frequency
- Osc. 3 Octave
- Osc. 3 Waveform
- Ext. Audio Level
- Osc. 1 Level
- Osc. 2 Level
- Osc. 3 Level
- Noise Level
- Filter Cutoff

- Filter Spacing
- Filter Resonance
- Filter KB Control Amount
- Filter Attack
- Filter Decay
- Filter Sustain
- Filter Release
- Filter Envelope Amount
- Volume Attack
- Volume Decay
- Volume Sustain
- Volume Release
- Master Volume
- Headphone Volume

The next parameter available in Pot Mapping is Direction. Choices are Normal or Inverted. Normal means, as the value of a Source is increased, the value to the Destination is also increased. Inverted means the opposite – as a Source’s value is increased the value to the Destination is decreased.

Finally, the Amount can be selected – 4 choices are available: Off, 25%, 50%, or 100%. The percentages refer to the percentage of the Destination’s total range that the Source affects.

Pot Mapping is a very powerful addition to the Voyager’s front panel controls – as it creates the ability to route controls to more than one destination. A simple use is for the controlling of Volume with the Keyboard’s Note On velocity, a common modulation in modern synthesizers. More arcane uses of Pot mapping exist, for instance, using the pitch Bend wheel to control Pitch bend and filter cutoff. This creates a timbral transformation of a sound as its pitch is being altered. The possibilities for expressive, personalized presets boggle the mind!

### 6.1 LFO MIDI CLOCK DIVIDER

When the LFO sync switch is set to MIDI, a MIDI Clock signal retriggers the start of the LFO cycle. The clock divider calculates a new retrigger signal based on the MIDI Clock signal. The divider has 96 values, with 48 divisions per beat. The values create the following rhythms:

- 96 = Half note = 2 beats of the MIDI Clock signal
- 72 = dotted quarter note = 1 ½ beats of the MIDI Clock signal
- 48 = quarter note = 1 beat of the MIDI Clock signal
- 36 = dotted eighth note = ¾ of a beat of the MIDI Clock signal
- 24 = eighth note = ½ of a beat of the MIDI Clock signal
- 16 = triplet eighth note = 1/3 of a beat of the MIDI Clock signal
- 12 = sixteenth note = ¼ of a beat of the MIDI Clock signal

### 6.2 INIT. PARAMETERS

INITIALIZE PARAMETERS is a function that allows the user to reset the current values of the Voyager’s parameters to a basic sound which can be used as a starting point for new sound development. Enter EDIT mode and use the +/- 1 buttons to highlight INIT. PARAMETERS. Press the ENTER button and the screen will prompt “Load the default Init. Parameters? Yes/No”. Use the cursor to select Yes and press ENTER. The parameters are as follows:

# DEFAULT PRESET

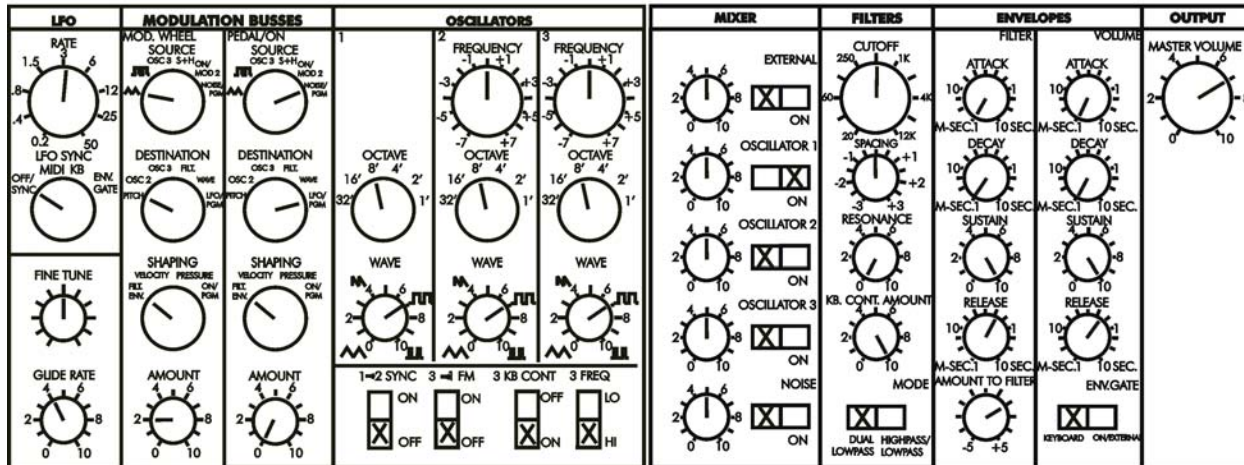

Glide OFF  
Release OFF

The default settings for the rest of the Voyager's parameters are as follows:

pitch bend amount ----- fourth  
 keyboard mode ----- lower key priority  
 trigger mode ----- single trigger  
 filter a ----- 4 pole  
 filter b ----- 4 pole  
 filter env gate ----- env gate input (jack)  
 amplitude env gate ---- env gate input (jack)

touch surface x dest. - filter cutoff  
 touch surface x ctrl. - off  
 touch surface x dir. -- normal  
 touch surface x amt. -- 50%  
 touch surface y dest. - filter spacing  
 touch surface y ctrl. - off  
 touch surface y dir. -- normal  
 touch surface y amt. -- 50%  
 touch surface a dest. - filter resonance  
 touch surface a ctrl. - off  
 touch surface a dir. -- normal  
 touch surface a amt. -- 50%  
 touch s. gate x dest. - no switch  
 touch s. gate x ctrl. - off  
 touch s. gate x dir. -- normal  
 touch s. memory busses no  
 touch s. memory global no

pot map 1 source ----- velocity attack  
 pot map 1 dest. ----- master volume  
 pot map 1 direction --- normal  
 pot map 1 amount ----- off

pot map 2 source ----- key pitch  
pot map 2 dest. ----- filter resonance  
pot map 2 direction --- inverse  
pot map 2 amount ----- off

pot map 3 source ----- mod. wheel  
pot map 3 dest. ----- filter spacing  
pot map 3 direction --- normal  
pot map 3 amount ----- off

pot map 4 source ----- foot pedal 1  
pot map 4 dest. ----- filter cutoff  
pot map 4 direction --- normal  
pot map 4 amount ----- off

midi clock divider ---- 24

preset name ----- "Preset xxx" (xxx = act. program number)  
"Default PROG"

#### PGM's

pgm mod. wheel source - noise  
pgm mod. wheel dest. -- lfo rate  
pgm pedal source ----- noise  
pgm pedal dest. ----- lfo rate  
pgm shaping 1 source -- 0 (fixed value)  
pgm shaping 2 source -- 0 (fixed value)

### 6.3 PRESET NAME

PRESET NAME is a function that allows the user to assign a name to a preset containing up to 24 characters on two twelve character lines. Characters are selected by moving the cursor to the desired character location and scrolling through the character list. The cursor can be moved with the CURSOR button, or by tapping the bottom half of the touchpad (referred to as T-S). Characters can be selected by using the +/-1 button, or by moving your finger horizontally across the top half of the touchpad. Available characters are:

<space> ! " # \$ % & ' ( ) \* + , - . / 0 1 2 3 4 5 6 7 8 9 : ; < = > ? @ A B C D E F G H I J  
K L M N O P Q R S T U V W X Y Z [ \ ] ^ \_ ` a b c d e f g h i j k l m n o p q r s t u v w x y z {  
| } ~

The Voyager's keyboard is also a data entry device for the naming of presets. It is fortuitous that the number of white keys on the Voyager's keyboard is 26 – the number of letters in the English alphabet! Thus the lowest note, F = "A" and the highest note, C = "Z" when used to enter letters in the Preset name function. The following is a list of the keys and their functions:

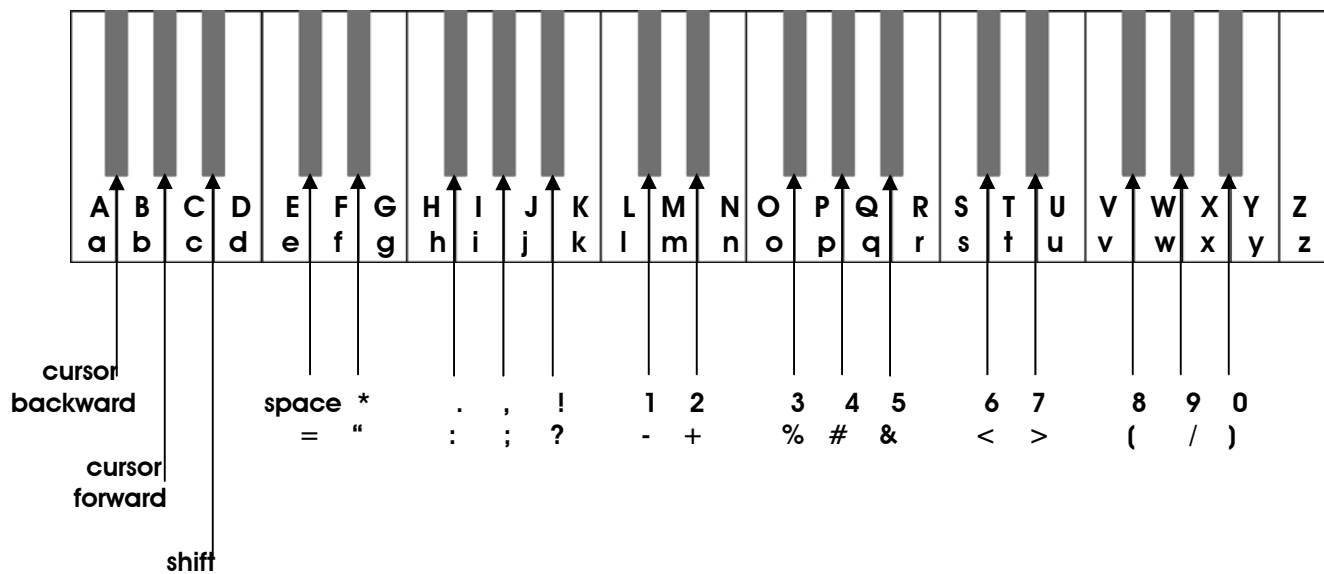

Once a name is entered, it must be saved to be stored in memory. Below is the routine for saving presets.

#### 6.4 SAVE PRESET

SAVE PRESET allows the user to store all the Voyager's current front panel settings, Pitch Bend Amount, Programmable Mod Sources and Destinations, Keyboard Mode, Trigger Mode, and Preset Name to one of 128 Memory locations. To save your edited sound, enter EDIT mode, use the +/- 1 buttons to highlight SAVE PRESET and press ENTER. The screen displays across the top line EDIT STORE TO PRESET X, where X is the current preset number. Below that, the preset name that is already stored in memory is displayed. Use the +/- 1 buttons to select the preset location where you want to store your current settings, then press ENTER. The screen then confirms your decision, and prompts you to select Yes or No. Use the cursor button to select Yes and press ENTER. The previously stored values for the selected preset are now replaced with your new values.

## 4. PANEL Mode

PANEL Mode is used to access presets and other performance functions. Pressing the PANEL button accesses PANEL mode. This lights the LED above the PANEL button, and the preset number is displayed. Note that the previous sound is stored until the ENTER button or the +1/-1 buttons are pressed. Once a preset is called up, parameters can be changed. If the original sound is desired, simply press ENTER and the original preset will be reloaded. ENTER stores the tweaked sound into a memory buffer that can be brought back through the RECALL function in EDIT mode. Once the program number is changed, the buffer is cleared.

There are 128 memory locations for presets, all of which can be overwritten by the user. The 128 presets are numbered 1 to 128. A preset consists of all the settings of the front panel controls except FINE TUNE, plus the parameters in EDIT mode.

Once a preset is called up, the knobs can be used to adjust the parameters of the sound. When a knob is changed and it is in a different position than the stored value, the value jumps to the position of the knob. If you make changes to a preset that you like – they can be saved in EDIT mode.

Once in PANEL mode, pressing the PANEL button accesses the PANEL mode Menu. There are four items in this menu:

QUICK MODE  
PARAMETER DISPLAY  
HEADPHONE VOLUME  
MASTER VOLUME

### QUICK MODE

QUICK MODE is used to determine whether the presets change by simply pressing the +1 or -1 button, or by a combination of +1/-1 and ENTER. QUICK MODE (+1/-1 changes presets) is ideal for auditioning Presets. Disabling QUICK MODE is designed for performing live, where the user may want to call up a new preset while continuing to play the current preset. The new preset only becomes active when the user presses the ENTER button.

### PARAMETER DISPLAY

PARAMETER DISPLAY is used to monitor changes to the values of a preset's parameters. When PARAMETER DISPLAY is active, a change in the position of a knob or switch on the front panel causes the display to show the preset's stored value and the new value simultaneously. The last parameter changed is displayed.

### HEADPHONE VOLUME

HEADPHONE VOLUME is used to determine whether the stored Headphone Volume value is loaded when a new preset becomes active. This is useful in case your presets have stored a high Headphone Volume value, or if you've changed to a different set of headphones and the volume is drastically louder than normal.

### MASTER VOLUME

MASTER VOLUME is used to determine whether the stored Master Volume value is loaded when a new preset becomes active. This is useful if your preset bank contains unusually loud presets, or presets with widely varying Master Volume values.

### RECEIVE SINGLE PRESET

This does not appear as an option in the Panel Menu – but is used in conjunction with “Receive Presets” in Master Mode. In Master Mode, make sure Sysex is enabled in “Receive Presets”. Once this is done, a single preset can be received to the current active preset location in Panel mode. Once a preset is received in the current active location, it can be auditioned. If you want that preset to become part of the Voyager’s preset bank, you must save the imported preset. If it is not saved and the current preset number is changed, the imported preset is wiped from the Voyager’s preset memory buffer. Using this function in conjunction with the “Send single preset” function in Master mode allows the mix and match of presets from different banks.

## COMPARE

Compare is a feature in Panel Mode, linked to the Edit Mode “Compare to Preset” function. Pressing the CURSOR activates this function – loading the sound in the Compare buffer, and pressing ENTER returns to the active preset. To load a Preset into the Panel Compare buffer, Go to Edit Mode, select Compare to Preset and press ENTER. Use the cursor to move to the Preset field. Press PANEL to go back to PANEL mode. Now when you press CURSOR, the preset should show as being loaded into the Compare buffer. It will remain there until the Compare function is used in Edit mode.

## 5. MIDI

Software Version 2.5 for the minimoog Voyager contains an extensive MIDI implementation. The MIDI channel for transmission and reception is selected in the MASTER mode. It is remembered after power down.

MIDI Transmission and Reception includes:

Note On messages: The Voyager is a monophonic synthesizer, and responds to Note On messages based on the Note Priority and Trigger Mode selected. Note On messages are transmitted polyphonically.

Program Change messages: Program Change Messages are transmitted by using the +/-1 Buttons.

All Notes Off: Transmitted by pressing the MASTER button in Panel Mode.

Pitch Bend

MIDI CCs (for the front panel controls) CC stands for continuous controller – a type of MIDI message used to produce variation in a sound. A CC message has a number (which describes what parameter is changed) and a value. All the front panel knobs and switches are assigned a CC number. Here is the list of Voyager parameters and CCs assigned to them. The following is a list of the Voyager's Front Panel Controls and the corresponding MIDI CCs:

Voyager Control	MIDI CC numbers
Mod Wheel	1 MSB 33 LSB
MOD 1	2 MSB 34 LSB (receive only)
MOD 2	4 MSB 36 LSB (receive only)
Release Switch	88 (Value 0-64=Off; 65-127=On)
Glide Switch	65 (Value 0-64=Off; 65-127=On)
Glide Rate	5 MSB 37 LSB
LFO Sync switch	67 (Value 0-31=Off; 32-63=MIDI; 64-95=KB; 96-127=Env. Gate)
LFO Rate	3 MSB 35 LSB
Mod Wheel Source	68 (Value 0-15=Tri; 16-31 = Squ; 32-47 = Osc. 3; 48-63=S+H; 64-79 = On/Mod2; 80-127=Noise/PGM)
Mod Wheel Destination	69 (Value 0-15=Pitch; 16-31 = Osc.2; 32-47 = Osc. 3; 48-63=Filt; 64-79 = Wave; 80-127=LFO Rate/PGM)
Mod Wheel Shaping	70 (Value 0-31 =Filt. Env.; 32-63=Velocity; 64-95=Aftertouch; 96-127=On/PGM)
Mod Wheel Amount	6 MSB 38 LSB
Pedal/On Source	71 (Value 0-15=Tri; 16-31 = Squ; 32-47 = Osc. 3; 48-63=S+H; 64-79 = On/Mod2; 80-127=Noise/PGM)
Pedal/On Destination	72 (Value 0-15=Pitch; 16-31 = Osc.2; 32-47 = Osc. 3; 48-63=Filt; 64-79 = Wave; 80-127=LFO Rate/PGM)
Pedal/On Shaping	73 (Value 0-31 =Filt. Env.; 32-63=Velocity; 64-95=Aftertouch; 96-127=On/PGM)
Pedal/On Amount	8 MSB 40 LSB
Osc. 1 Octave	74 (Value 0-15 = 32'; 16-31 = 16';

	32-47 = 8'; 48-63 = 4'; 64-79 = 2'; 80-127 = 1')
Osc. 1 Waveform	9 MSB 41 LSB
Osc. 2 Frequency	10 MSB 42 LSB
Osc. 2 Octave	75 (Value 0-15 = 32'; 16-31 = 16'; 32-47 = 8'; 48-63 = 4'; 64-79 = 2'; 80-127 = 1')
Osc. 2 Waveform	11 MSB 43 LSB
Osc. 3 Frequency	12 MSB 44 LSB
Osc. 3 Octave	76 (Value 0-15 = 32'; 16-31 = 16'; 32-47 = 8'; 48-63 = 4'; 64-79 = 2'; 80-127 = 1')
Osc. 3 Waveform	13 MSB 45 LSB
1 → 2 Sync	77 (Value 0-64=Off; 65-127=On)
3 → 1 FM	78 (Value 0-64=Off; 65-127=On)
3 KB Control	79 (Value 0-64=Off; 65-127=On)
3 Frequency Lo/Hi	80 (Value 0-64=LO; 65-127=HI)
External Audio Level	14 MSB 46 LSB
External Audio On/Off	81 (Value 0-64=Off; 65-127=On)
Osc. 1 Level	15 MSB 47 LSB
Osc. 1 On/Off	82 (Value 0-64=Off; 65-127=On)
Osc. 2 Level	16 MSB 48 LSB
Osc. 2 On/Off	83 (Value 0-64=Off; 65-127=On)
Osc. 3 Level	17 MSB 49 LSB
Osc. 3 On/Off	84 (Value 0-64=Off; 65-127=On)
Noise Level	18 MSB 50 LSB
Noise On/Off	85 (Value 0-64=Off; 65-127=On)
Filter Cutoff	19 MSB 51 LSB
Filter Spacing	20 MSB 52 LSB
Filter Resonance	21 MSB 53 LSB
Filter KB Control Amount	22 MSB 54 LSB
Filter Mode	86 (Value 0-64=Off; 65-127=On)
Filter Envelope Attack	23 MSB 55 LSB
Filter Envelope Decay	24 MSB 56 LSB
Filter Envelope Sustain	25 MSB 57 LSB
Filter Envelope Release	26 MSB 58 LSB
Filter Envelope Amount to Filter	27 MSB 59 LSB
Volume Envelope Attack	28 MSB 60 LSB
Volume Envelope Decay	29 MSB 61 LSB
Volume Envelope Sustain	30 MSB 62 LSB
Volume Envelope Release	31 MSB 63 LSB
Envelope Gate Switch	87 (Value 0-64=Off; 65-127=On)
Master Volume	7 MSB 39 LSB

## MIDI CLOCK

When the LFO SYNC switch is set to "MIDI", a MIDI clock signal retriggers the start of the LFO cycle, similar to the way Oscillator Sync works. Because the Voyager has an analog LFO – the LFO Rate itself is not automatically set to the clock frequency – just the start of the LFO cycle. Adjusting the LFO Rate to a different rate relative to the MIDI clock signal can yield some interesting LFO patterns. To learn how to use this:

- Call up a preset that has audible LFO modulation and a sustaining tone.
- Switch the LFO sync switch to MIDI. Make sure the Clock divider value is maximum.
- Send a MIDI clock signal to the Voyager.
- Now, slow the LFO rate down all the way, and play a note and hold it. You should here the LFO triggered at every second MIDI tick. Now increase the LFO rate until it closely matches the half note tempo of the song. You have now synced the LFO to the tempo of the music. Because the LFO is triggered by the MIDI clock, it can't drift off tempo.

## System Exclusive

SysEx messages transmitted and received include Single Presets, Preset Banks, Operating System (System ROM) and Boot System.

## **Appendix A: Caring for your Voyager**

Clean the Voyager with a soft, moist cloth only – do not use solvents or abrasive detergents. The finish of the wood cabinet can be cleaned with a guitar polish, or a fine furniture polish. Heed the safety warnings at the beginning of the manual. Don't drop the unit. If shipping your Voyager, we recommend the original shipping carton, or an ATA approved Road Case. *Shipping the Voyager in a non-ATA or packaging other than the original carton will void the warranty.* When setting up the Voyager, be sure your stand or table is capable of holding at least 50 lbs.

Other maintenance of the Voyager should be referred to qualified service personnel. There are no user serviceable parts inside the chassis.

## **Appendix B: Service and Tech Support Information**

Your Voyager Performer Edition has a 1 year limited warranty. This warranty covers parts and labor, but excludes normal wear and tear and catastrophic occurrences. You should refer to the warranty registration for the exact terms and conditions. Should you develop problems with your Voyager please contact Moog Music tech support (by email [techsupport@moogmusic.com](mailto:techsupport@moogmusic.com)) and describe your problem in as much detail as possible. You may also contact tech support at 828-251-0090.

## Appendix C: List of Presets

There are a total of 128 presets in a Voyager bank. There are 128 presets in the factory bank of sounds shipped with the Performer Edition. These were written by the sound designer and composer Zon Vern Pyles, ranging from classic Moog sounds to the outer reaches of the Voyager's synthesis capabilities. Thanks for the sounds, Zon!!!

The following is a list of the preset names. Many are self-explanatory – they're all worth exploring...

### Minimoog Voyager Performer Edition factory patches

#	name
001	- I'm Ba-aack!!
002	- Chiffy Lead
003	- Brassy Lead
004	- Robo Vox
005	- Growing Lead
006	- X-tra low Bass
007	- Mellow Hammer
008	- Hollow Bass
009	- Brain Salad Buzz
010	- Gurglet
011	- Cyclor mod (wheel up)
012	- Wetness (wheel up)
013	- Animated (wheel up)
014	- He was lucky
015	- Tympanic membrane
016	- Kinda saxy
017	- Analog Daze
018	- Heartbeat
019	- Electric Room
020	- Monica
021	- Wheel Bass
022	- Vowel Bass (wheel up)
023	- Slippery Lead
024	- Classic Ripper
025	- Toad Bass
026	- Velocity Bass
027	- Velowave Bass
028	- Funny Vox
029	- Minor Glider
030	- Prog Lead
031	- Forever Lead
032	- Here it comes
033	- Panning Throbber

034 - Zappy Bass  
035 - Classic Sweeper  
036 - Touchpad sync  
037 - First Love  
038 - Clearly fuzzy  
039 - Fond Memories  
040 - Flyin' fingers  
041 - Worms of funk  
042 - Tremowah Bass  
043 - Welcoming machine  
044 - Touchpad horn  
045 - Still fun (wheel up)  
046 - Subfood Bass  
047 - Firm bottom  
048 - Lunar News (wheel up)  
049 - Seafoam (wheel up)  
050 - Wheel talker  
051 - Living Bass  
052 - Pucker up  
053 - Lil' delay  
054 - Utopian Lead  
055 - Bouncer (wheel up)  
056 - Stereo Zaps  
057 - In the pocket  
058 - Going Baroque  
059 - Flutey  
060 - Relaxed Bass  
061 - Mystery metal  
062 - "B" drone jam  
063 - No knives please  
064 - Topographic melodies  
065 - Familiar growl  
066 - Make it sing  
067 - For Ripley  
068 - Other life  
069 - Epiphany  
070 - Crop circle delivery  
071 - Swamp life  
072 - Spartacus  
073 - Horn of Mythos  
074 - Call of the Gearpig  
075 - Soft as I remember  
076 - Stereo S&H (wheel up)  
077 - Harmonized (wheel up)  
078 - Sasquatch speaks up  
079 - Bo  
080 - Some funk for ya'  
081 - Bubbly Lead  
082 - Synthworld

083 - Aleatoric  
084 - Wheel chorus Lead  
085 - Glass Temple  
086 - Repeater Bass  
087 - Electro Kid  
088 - Fuzzy Lead  
089 - Catherine of Aragon  
090 - Catherine Howard  
091 - Anne Boleyn Bass  
092 - Anne Boleyn Lead  
093 - Raw & melodic  
094 - Sweepy Bass  
095 - Green Fog  
096 - Wrong Crypt  
097 - Just the harmonics  
098 - Thematic  
099 - Plucky Bass  
100 - Bright Bass  
101 - Tubby Bass  
102 - Alien Metal  
103 - NOT Unplugged  
104 - Bass Phenomena  
105 - Reedy Bass (use wheel)  
106 - Dramatic Entrance  
107 - Flying Toy  
108 - Alley Cat  
109 - Speedway  
110 - Call the plumber  
111 - Sweet Thing  
112 - Tribal  
113 - Plucked Lead  
114 - Hollow Fuzzytone  
115 - Sizzle Bass  
116 - Fly by  
117 - Short lived  
118 - What the...  
119 - Harpsinotes  
120 - Not small  
121 - Tiny flute  
122 - Cosmic chatter  
123 - Ridin' the storm out  
124 - Large fifths  
125 - Fanfare  
126 - Synergistic  
127 - Bass for E. Vonallen  
128 - Windy night

Appendix D:

MIDI IMPLEMENTATION CHART

Moog Music Inc.

03/04/04

Minimoog Voyager		MIDI Implementation Chart		Version 2.5/030404
Function...		Transmitted	Recognized	Remarks
<b>Basic</b> Default		<b>1-16</b>	<b>1-16</b>	Memorized
<b>Channel</b> Changed		<b>1-16</b>	<b>1-16</b>	Memorized
<b>Mode</b> Default		<b>3</b>	<b>4*</b>	*Note Priority is user selectable **All Notes Off
Messages		<b>X</b>	<b>O**</b>	
Altered		<b>X</b>	<b>X</b>	
<b>Note Number</b>		<b>0-127</b>	<b>0-127</b>	
True Voice		*****	<b>0-127</b>	
<b>Velocity</b> Note On		<b>O</b>	<b>O</b>	
Note Off		<b>O</b>	<b>O</b>	
<b>After Touch</b>		<b>O</b>	<b>O</b>	
<b>Pitch Bend</b>		<b>O</b>	<b>O</b>	
<b>Control Change</b>		<b>O†</b>	<b>O*</b>	†Transmit CC1-31 MSB, 33-63 LSB; CC 65-127; *Receives CC 1-31 MSB, 33-63 LSB; 65-88
<b>Program Change</b> True #		<b>O</b> <b>0-127</b>	<b>O</b> <b>0-127</b>	
<b>System Exclusive</b>		<b>O</b>	<b>O</b>	Must be enabled
<b>System Common</b>		<b>X</b>	<b>X</b>	
<b>System Real Time</b>		<b>X</b>	<b>X</b>	
<b>Aux Messages</b>		<b>X</b>	<b>X</b>	
<b>Notes</b>				†* See User Documentation for list of parameters and their corresponding CCs

Mode 1: Omni On, Poly

Mode 2: Omni On, Mono

**O: Yes**

Mode 3: Omni Off, Poly

Mode 4: Omni Off, Mono

**X: No**

## Appendix E:

### VX-351 User's Guide

#### Introduction

Flash back to the late 60's....

Back in the day, a synthesizer was a behemoth of panels and patch cords. They were known as modular synthesizers, because each function of the synthesizer was contained in a single module. A synthesizer was a collection of modules, and the instrument produced no sound until the proper connections were made by patch cables, from module to module. This approach afforded the synthesist serious creative flexibility – and the results of creative “what if I tried this?...” type of thinking yielded amazing results. The downside of this approach to synthesis is:

- Space – a good modular synth takes a lot of space.
- Time – coming up with a sound from the ground up takes a lot of practice, patience, and time.
- Repeatability – documenting a creative sound is laborious and not always accurate
- Mucho dinero \$\$\$\$\$\$ - a good modular synth takes serious dough to build.

Enter the minimoog – a portable synthesizer where the most musically useful connections in a synthesizer are made and permanently wired. Sounds can be made quickly with the knobs and switches of the well laid out front panel. They are easier to document with patch templates, and the synth can actually be CARRIED to gigs. Imagine that! Finally – a serious synthesizer made for the working musician.

Flash forward to today... The minimoog Voyager...

The Voyager is based on the concept of the minimoog. It is a portable analog synthesizer with all the basic connections for making great electronic sounds. In fact, from its front panel, it has even more functions than the original minimoog! People rave about the sounds they can get out of the Voyager – from classic synth tones to unheard of effects... But just when you thought you had heard it all from the Voyager, Moog Music introduces to you ... the VX-351 CV Expander!

Take a quick peak at the back of your Voyager and you will notice a plethora of jacks color coded with red and blue nuts – you may also notice a 25-pin “D” connector, labeled “accessory port” .... What does it all mean? The jacks that have the color-coded nuts are all INPUTS, the red ones are for control voltages, and the blue ones are for gates. The pins of the accessory port are all OUTPUTS – control voltages and gates.

Hmmm... control voltage and gate outputs and inputs.... it sounds like a modular synth! But how do you get the outputs back to the inputs?

*...Enter the VX-351!*

The VX-351 Voyager CV expander is an add-on product to your Voyager that contains all the CV and gate outputs on ¼” jacks. There are a total of 19 CV outputs and 2 gate outputs. In addition there are two attenuators, for reducing the strength of a CV signal, and two 4-way mults for sending a single CV signal to multiple control destinations. The supplied cable connects the VX-351 to the Voyager's

accessory port. With the VX-351, be prepared to have a lot of fun making new sounds with your Voyager!

The following instructions cover...

- Getting Started
- Understanding the VX-351
- Documenting your work
- Using the VX-351 and the minimoog Voyager together
- Adding a moogerfooger® CP-251 to the mix...
- Connecting other CV compatible equipment.
- Technical Information

### **GETTING STARTED with the VX-351**

**Important! Please read the instructions before attempting to use the VX-351 with your minimoog Voyager!**

1) Inspect the contents of the carton. It should include:

- The VX-351
- A 6' cable with db-25 connectors on each end.
- An Output adapter – to be installed inside the Voyager. The adapter must be installed prior to connecting the VX-351.
- An installation guide for the Output adapter.

You will need the following:

- A place close to your Voyager to set your VX-351 – if you have purchased the optional rack mount kit for the VX-351 you'll need a 19" equipment rack with 3 available spaces.
- Some ¼" patch cables for connections between the VX-351 and the Voyager – the more the merrier – choose lengths that are convenient to use without the "spaghetti" effect.

1) The first step is installing the VX-351 output adapter. For this procedure refer to the installation guide. The adapter must be installed in these units to ensure proper operation of the VX-351.

2) Locate the male end (the end with recessed pins) of the DB-25 cable – this is the end that plugs into the connector on the Voyager's back panel labeled "ACCESSORY PORT". Align the cable properly and make the connection. Use the thumbscrews to lock the connection. *Be careful not to force or cross thread the thumbscrews in the accessory port's female threads.* Following this, connect the other end of the cable to the connector on the VX-351 labeled "FROM ACCESSORY PORT".

## Basic Connection of the Voyager to the VX-351 CV Expander

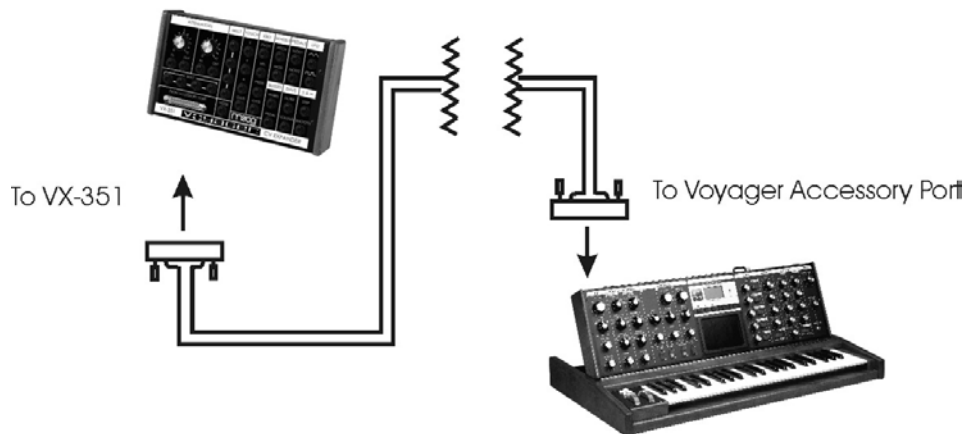

3) Now let's start with a basic sound and see how the VX-351 can work with the Voyager.

- Power up the Voyager – press the EDIT button.
- In the EDIT menu select "Init. Parameters", press ENTER, select YES and press ENTER again. This loads the default Voyager sound.
- Take one of your 1/4" cables – plug one end into the VX-351's LFO triangle output. Plug the other end into the Voyager's Filter control input.
- Play a note on the Voyager – you will hear the LFO modulating the Filter's Cutoff. Changing the RATE of the LFO will change the rate that the Filter cutoff goes up and down. This demonstrates a basic patch with the VX-351. With all the CV and Gate connections you make it is important to think of a Source (or Output), in this case the LFO triangle wave, and a Destination (or Input), in this case the Filter Control Input.
- Now, disconnect the cable from the Voyager's Filter Control and connect it to the IN of one of the Voyager's Attenuators. Set the Attenuator amount to Zero. Take another 1/4" cable and connect it from the VX-351 Attenuator OUT to the Filter Control Input.
- Play a note and gradually increase the Attenuator amount. You will notice that the amount of modulation will increase. An Attenuator is used to set the amount of a CV Source that passes to the Destination.

This is a very basic use for the VX-351 – but it shows the fundamental concept of how to use it: source goes to destination. Using this fundamental concept, you can patch together additional modulation – and get as complex as you like. What follows is a detailed explanation of the output signals and the other functions contained in the VX-351.

## Understanding the VX-351

The VX-351 is organized by section – similar outputs are grouped together. Here's the rundown...

### **TOUCH**

This group of outputs is generated from the Touch Surface Controller. There are three CVs (X, Y, and A) and one gate signal.

**X:** This is the CV generated by left to right (horizontal) position of contact with the touch surface.

**Y:** This is the CV generated by up and down (vertical) position of contact with the touch surface.

**A:** This is the CV generated by the amount of area covered on the touch surface.

**GATE:** This is a gate signal generated by contact with the touch surface. When contact is made, the Gate is ON and when no contact is made the gate goes OFF.

### **KBD**

This group of outputs is generated from the Voyager's Keyboard. There are three CVs (Pitch, Velocity and Pressure) and one gate signal.

**PITCH:** This is the CV determined by the note that is played on the Keyboard. It is the same voltage used for determining the pitch of the Voyager's Voltage Controlled Oscillators.

**VEL:** This is the CV determined by the velocity used to depress a key.

**PRESS:** This is the CV determined by how much pressure is exerted on a key after it is depressed.

**GATE:** This is the gate signal generated when a key is depressed.

### **WHEELS:**

This group of outputs is generated from the Left Hand Controller Wheels.

**PITCH:** This is the CV generated from the Pitch Wheel.

**MOD:** This is the CV generated from the Mod Wheel.

### **PEDALS:**

This group of outputs is generated from the MOD1 and MOD2 jacks on the rear panel of the Voyager.

**MOD1:** This is the CV generated from the MOD1 input. The MOD1 Input is a CV input on the Voyager that determines how much of the PEDAL/ON Mod Bus Source goes to the PEDAL/ON Mod Bus Destination. With nothing plugged into the MOD1 jack, the voltage that's present at the MOD1 jack is +5V. When a CV is plugged in to the MOD1 input, that voltage replaces the +5 Volt signal at the MOD1 Input. The Voltage that appears at the MOD1 Input is duplicated at the MOD1 output.

**MOD2:** This is the CV generated from the MOD2 input. The MOD2 Input is a CV input on the Voyager that is an external modulation source for the Mod Busses. With nothing plugged into the MOD2 jack, the voltage that's present at the MOD2 jack is +5V. When a CV is plugged in to the MOD2 input, that voltage replaces the +5 Volt signal at the MOD2 Input. The Voltage that appears at the MOD2 Input is duplicated at the MOD2 output.

**LFO:**

This group of outputs is generated from the Voyager's LFO (Low Frequency Oscillator) circuit. There are two CV waveforms here – triangle and square

**TRIANGLE:** This is the triangle wave output of the LFO.

**SQUARE:** This is the square wave output of the LFO.

**BUSSES:**

This group of outputs is generated by the Mod Buss signals. They are the Modulation source after being shaped by the SHAPING signal at the level determined by the AMOUNT control and the MOD WHEEL or signal at the MOD1 Input jack

**WHEEL:** This is the output of the Mod Wheel Mod Buss. It is the Mod Wheel SOURCE shaped by the SHAPING signal. The level is determined by the AMOUNT control and the MOD WHEEL.

**PEDAL:** This is the output of the Pedal/On Mod Buss. It is the Pedal/On SOURCE shaped by the SHAPING signal. The level is determined by the AMOUNT control and the signal at the MOD1 Input jack.

**ENVS**

This group of outputs is the output of the Envelope Generators.

**FILTER:** This is the CV output of the Filter Envelope Generator.

**VOLUME:** This is the CV output of the Volume Envelope Generator.

**S & H**

This group of outputs is generated by the Sample and Hold Circuit.

**STEP:** This is the output of the Sample and Hold Circuit.

**SMOOTH:** This is the Smoothed output of the Sample and Hold Circuit.

**ATTENUATORS**

The VX-351 contains two attenuators. An attenuator is used to reduce the amount of a CV signal. The attenuators have an input jack, an output jack, and a knob. The knob sets the amount of the signal present at the input jack that passes to the output jack. When the knob is set to fully clockwise, the full input signal passes to the output.

**MULT**

The VX-351 contains two 4-way mults. A mult is used to distribute a single source to multiple destinations. An example is sending the Voyager's LFO To the Volume, Filter and Pan Control Inputs. In this case all three of those parameters will be controlled simultaneously by the LFO. **WARNING:** A mult is NOT a mixer. Do not apply more than one CV source or CV output to a mult! (For example combining the LFO triangle and LFO square wave to go to the Filter Input) Combining CVs in a Mult can cause them to add together in a way that can be damaging to some control inputs! Don't do it!!! You must use a CV mixer, like the CP-251 Control Processor's Mixer to combine CV outputs.

These are the components that make up the VX-351 – there's quite a bit you can do!

## Documenting your work

One thing to keep in mind is that although the Voyager can remember the settings of the front panel controls as a preset, it cannot save the routings of patch cables or the positions of the attenuators. We recommend having a list of the outputs with a space to document destinations like so:

Source	Destination
Touch X	
Touch Y	
Touch A	
Touch Gate	
KBD Pitch	
KBD Velocity	
KBD Pressure	
KBD Gate	
Pitch Wheel	
Mod Wheel	
MOD1	
MOD2	
LFO Triangle	
LFO Square	
Mod Wheel Mod Bus	
Pedal/On Mod Bus	
Filter Env	
Vol Env	
S&H Step	
S&H Smooth	
Noise	
Atten. 1/amount	
Atten. 2/ amount	
Mult A1	
Mult A2	
Mult A3	
Mult B1	
Mult B2	
Mult B3	
Notes:	Use w/ Preset # _____

This approach is simple but effective.

## Using the VX-351 and the minimoog Voyager together

The following are some ideas for using the VX-351 with the minimoog Voyager.

### A) Mod wheel controls amount of both Mod Buss signals.

This is a really useful way to use the Mod Wheel as a controller for more than one type of modulation. To try this out, go through the following steps:

- Initialize the Voyager's parameters (Init. Parameters in the Edit Menu)
- Set the Pedal/On Mod Buss Source to Square wave, set the Pedal/On Destination to Filter. Set Shaping to ON and Amount to 5.
- Using a ¼" cable, connect the VX-351 Mod Wheel output to the Voyager's MOD1 Control Input.
- Play a note and move the Mod Wheel forward. You'll hear both Triangle wave modulation of the pitch, and square wave modulation of the Filter fade in.

This is a useful patch that can be used on a variety of patches where you want two types of modulation to fade in by using the Mod Wheel.

### B) Mod buss signal modulates more than one destination.

This is a way to use one Modulation signal to control more than one destination. Try the following:

- Initialize the Voyager's parameters.
- Using a ¼" cable, connect the Mod Wheel Mod Buss output to the Voyager's Filter Control Input.
- Play a note and move the mod wheel forward. You'll hear the LFO triangle wave modulating both the Voyager's Pitch, and Filter.
- A variation of this would be to insert an Attenuator in between the Mod Wheel Mod Buss output and the Filter Input. This way you can adjust the amount of modulation that goes to the filter.

### C) Pressure controls Pedal/On Mod buss amount.

Just as you can use an Expression pedal plugged into the MOD1 input to control the Pedal/On Mod Buss, You can use another signal that varies in the same range to perform the same function. The Pressure signal from the Voyager's keyboard is a good example of this. Try the following:

- Initialize the Voyager's parameters.
- Set the Pedal/On Mod Buss Source to square wave, Destination to Filter, Shaping to On, and Amount to 5.
- Using a ¼" cable, connect the VX-351 KBD Pressure output to the Voyager's MOD1 Input.
- Play a note and press down the key you are playing – the Modulation of the filter should increase as you add pressure, and disappear when you're not pressing hard at all.
- As a variation, switch the Pedal/On Mod Buss Source to On. Now play a note – pressing down makes the filter brighter.

### D) LFO triggers Voyager's Envelopes

This is an alternative to triggering a sound from the Voyager by pressing a key. The last key pressed will determine the pitch, but the LFO will trigger the start of the envelopes.

- Initialize the Voyager's parameters
- Using a ¼" cable, connect the VX-351 LFO Square Output to the Voyager's Envelope Gate Input.
- Switch the Envelope Gate switch at the bottom right corner of the front panel to "On/External". You should immediately hear a note repeating at the LFO rate.

These are just a few examples of the functions that a VX-351 adds to a Voyager.

### **Adding a moogerfooger CP-251 to the mix**

The VX-351 works incredibly well alongside the moogerfooger CP-251 Control Processor. The CP-251 brings a CV mixer, another mult, a pair of attenuators, an extra LFO, sample and hold circuit, a lag processor and noise source to the table. The combination of Voyager, VX-351, and CP-251 is very much like having a small Modular synthesizer. The nice thing is that the most basic connections are already made in the Voyager – and the VX-351/CP-251 combo adds more modulation possibilities.

The following examples use the CP-251 in addition to the Voyager. These patches can get a little more complicated – make sure you have plenty of good patch cables handy!

#### **A) Inverting the keyboard CV to the Filters**

This is a handy little trick that can be used to lower the filter Cutoff as you play higher on the keyboard. This is similar to certain acoustic instruments like a cello, whose tone gets duller as higher notes are played.

- Initialize the Voyager's parameters.
- Turn the Voyager KB. Cont. Amount down to 0
- Using a ¼" cable, connect one end to the VX-351 KBD Pitch Output. Connect the other end to the CP-251 Mixer 1 Input.
- Using a ¼" cable connect one end to the CP-251 Mixer inverting (-) out, connect the other end to the Voyager's Filter Cutoff Input.
- Set the CP-251's Mixer 1 Input level and the Output level to 10. Set the Offset control in mid position.
- Play a scale up the keyboard, from low to high, notice that the sound gets much duller. Adjust the Output Level of the CP-251 and the Offset amount to taste.

#### **B) Lag generator used to add glide to Filter**

This is a way to apply a portamento effect to the Filters of the Voyager.

- Initialize the Voyager's parameters.
- Using a ¼" patch cable, connect one end to the VX-351 KBD Pitch output, connect the other end to the CP-251's Lag Processor Input.
- Using another ¼" patch cable, connect one end to the CP-251's Lag Processor Output, and the other end to the Voyager's Filter Control Input.
- Turn on the Voyager's glide switch. Play notes at opposing ends of the keyboard, adjust the Rise and Fall time of the Lag Processor to match the up and down filter portamento to the up and down pitch portamento.

### **C) Sample and hold staircase patterns**

A Sample and Hold circuit can be used for more than generating random voltages. One type of modulation pattern that can be achieved is called "Staircase" modulation. It is achieved by feeding a slow triangle wave into the sample and hold input – with a trigger signal like a LFO at a faster rate, the output looks like the triangle wave is chopped up into "stairs" at the trigger LFO rate.

- Initialize the Voyager's parameters. Set the Voyager's LFO rate to about .8 Hz.
- Using a ¼" patch cable, connect the VX-351's LFO triangle output to the Voyager's Sample and Hold Input (the red one).
- Set the CP-251's LFO rate to about 6 Hz.
- Using another ¼" cable, connect the CP-251's LFO square wave output to the Voyager's Sample and Hold Gate Input (the blue one).
- Select S&H as the Voyager's Mod Wheel Mod Buss Source.
- Play a note and move the Mod Wheel forward. You should hear the pitch modulated by a staircase waveform.

### **D) Envelope to Noise level for noise component at the attack of a note.**

Some sounds have a burst of noise at the beginnings of a note or "chiff" – for instance a flute or a pipe organ. This patch digs a little deeper into the Voyager to achieve this effect.

- Initialize the Voyager's parameters.
- Set the Osc. 1 waveform to Triangle wave
- Set the Filter Envelope to the following settings: Attack 1 msec, Decay, 100 msec, Sustain 0, Release can be Off.
- Using a ¼" patch cable, connect the VX-351 Filter envelope Output to the CP-251 Mixer 1 input.
- Set the CP-251 Mixer 1 Input level and the Output level to 10, Set the Offset to – 2.5.
- Using a ¼" cable, connect the CP-251 Normal (+) Mixer Output to the Voyager's MOD2 Input.
- In the Voyager's Pedal/On Mod Buss, make the following settings: Source: On/MOD2, Destination: LFO/PGM, Shaping: On, Amount 10.
- In the Edit menu select "Pedal PGM Dest" and press ENTER.
- In the list of programmable destinations, select Noise level.
- In the Voyager's Mixer section, turn ON the Noise signal. Turn up the level to 5.
- Set the Voyager's Filter Envelope Amount to Filter control to +2.
- In the Edit Menu select "Trigger Modes". Set the trigger mode to Multi-triggering.
- Now when you play a note, you should hear a noise component at the beginning of the note. Playing with a combination of Filter Envelope times, Filter cutoff, Noise Level, and Pedal/On Mod Buss amount will make this effect more or less perceptible. Selecting Oscillator Levels as the Programmable Mod Destination can yield some interesting effects as well.

These are just scratching the surface of the synthesis possibilities afforded by the Voyager, the VX-351, and a CP-251.

## Connecting other CV compatible equipment

We've covered some basic uses of the Voyager and the VX-351 – and even added a CP-251 to the mix. Other CV compatible equipment like our moogerfooger analog effects can be added to liven up the proceedings. Other CV compatible equipment can be connected as well. Keep in mind that you should always connect a source to a destination, and that you shouldn't combine multiple CVs to a single destination without a mixer.

Here are some things you could try with a Voyager, a VX-351 and our moogerfoogers:

- Use the Voyager's Filter envelope to control the Sweep of a MF-103 12-stage Phaser.
- Use the Voyager's Mod Wheel to control the Rate of the MF-103 12-stage Phaser.
- Use the Voyager's Mod Wheel to control the Mix of Ring Modulation on a MF-102.
- Use the Voyager's Touch surface to control the MF-102's Carrier Oscillator Frequency.
- Use the Noise Output to add Roughness to a MF-101's Filter Cutoff.

This list could go on and on...

As you can gather – there are many, many possibilities for exploring synthesis – whether you are trying to duplicate a sound or effect you've heard, or if you are trying to make a sound that nobody's heard before. Experimentation is part of the fun!

### Technical Information

The following is technical information about the VX-351's outputs.

#### TOUCH

**X:** -5 to +5 V, 330  $\Omega$  output impedance

**Y:** -5 to +5 V, 330  $\Omega$  output impedance

**A:** -5 to +5 V, 330  $\Omega$  output impedance

**GATE:** +5 V On, 0 V Off; 1,000  $\Omega$  output impedance (TTL)

#### KBD

**PITCH:** -0.85 to +2.52 V; This is the Keyboard Pitch voltage range when the Voyager's keyboard is played. The range will be different when MIDI note-on messages are received; The Keyboard Pitch Voltage changes by 0.935 volts per octave; 330  $\Omega$  output impedance.

**VEL:** -5 to +5 V, 330  $\Omega$  output impedance.

**PRESS:** -5 to +5 V, 330  $\Omega$  output impedance

**GATE:** +5 V On, 0 V Off; 1000  $\Omega$  output impedance (TTL)

#### WHEELS

**PITCH:** -5 to +5 V, 330  $\Omega$  output impedance

**MOD:** -5 to +5 V, 330  $\Omega$  output impedance

#### PEDALS

**MOD1:** -5 to + 5 V, +5 V w/nothing connected to MOD 1 input. 330  $\Omega$  output impedance.

**MOD2:** -5 to + 5 V, +5 V w/nothing connected to MOD 2 input. 330  $\Omega$  output impedance.

#### **LFO**

**TRIANGLE:** -2.5 to +2.5 V, 330  $\Omega$  output impedance

**SQUARE:** 0 to +3 V, 330  $\Omega$  output impedance

#### **BUSSES**

**WHEEL:** Max. Outputs -4 to +4 V Nominal, 1000  $\Omega$  output impedance.

**PEDAL:** Max. Outputs -4 to +4 V Nominal, 1000  $\Omega$  output impedance.

#### **ENVS**

**FILTER:** 0 to +5 V, 330  $\Omega$  output impedance.

**VOLUME:** 0 to +5 V, 330  $\Omega$  output impedance.

#### **S & H**

**STEP:** Max. -2 to +2 V Nominal, 330  $\Omega$  output impedance.

**SMOOTH:** Max. -2 to +2 V Nominal,  $\Omega$  output impedance.

**Moog Music Inc.**  
**554C Riverside Dr**  
**Asheville, NC 28801**  
**800-948-1990**  
**[www.moogmusic.com](http://www.moogmusic.com)**

**Minimoog Voyager User's Manual SKU#MAN-MIN-01**