

1. Introduction

Before installing the A-190-4 please read the **important note on page 5!**

The **A-190-4** is a **MIDI-CV/SYNC Interface**, capable to control any A-100 Module via MIDI that provides CV and gate/trigger input sockets.

The A-190-4 has **two Digital-to-Analogue converters** (DAC for short), which put out control voltages from -3V to +10V (CV1) and 0V to +10V (CV2), so that you can control not just pitch, but also another voltage-controllable parameter of your synthesizer.

DAC1 is 'hard-wired' to receive MIDI **note messages** and convert them into control voltages available at CV output socket **CV1**. The DAC has 12-bit resolution, which gives excellent tuning resolution (in steps of 1/4096th). Usually, DAC1 will be used to **control VCO pitch**.

DAC2 can be assigned to a **MIDI controller**. It has also 12-bit resolution in order to allow smooth parameter changes. Its output is available at **CV2 socket**, and can be used for voltage control of any suitable module (eg. VCF, VCA, etc.).

The A-190-4 also has a **clock output**, controlled by **MIDI clock**. Incoming MIDI clock can be divided down to provide a variety of clock rates that enable vintage sequencers or drum machines to be synced to MIDI.

A **Reset Output** provides control of the A-160 / 161 Clock Divider / Sequencer or can produce MIDI-triggered gates (e.g. for an ADSR). When receiving a MIDI START or CONTINUE message the voltage at the Reset output is set to "off". Receiving a MIDI STOP message generates a voltage level at the output.

In addition, the A-190-4 module features **portamento** (glide), **pitchbend** and provides a software generated **LFO**.

All parameter settings can be saved in a **non-volatile memory**.

All functions can be easily controlled by a simple, **menu driven user interface**.

2. Overview

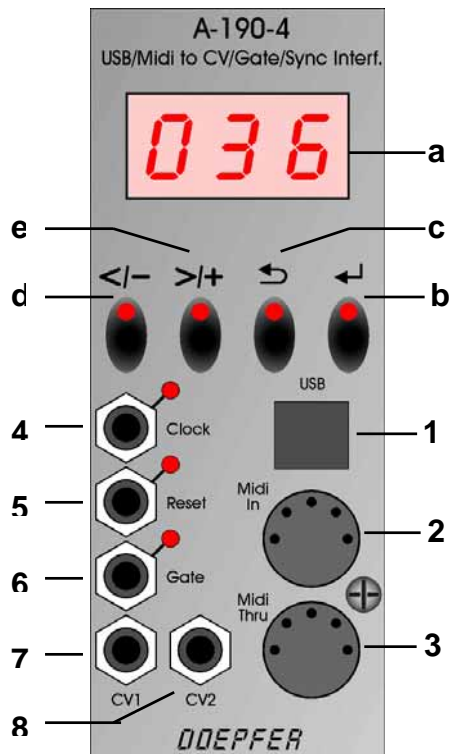

Controls and Display:

- a. **Display** : Three-digit LED display shows abbreviations of functions and parameter names as well as parameter values.
- b. **Return** : Opens up a sub function resp. takes you to the next lower level of the menue structure (**down**). It also has to be pressed to confirm some functions.
- c. **Escape** : Takes you back to the next higher level of the menue structure (**up**). It may also be used to cancel certain functions.
- d. **</-** : Takes you back to the previous function / parameter on the current menue level (**backwards**). It also decreases a parameter value by one step at a time. When pressed down continously for approx. three seconds or longer, the value change will be accelerated.
- e. **>/+** : Takes you to the next function / parameter on the current menue level (**forward**). It also increases a parameter value by one step at a time. When pressed down continously for approx. three seconds or longer, the value change will be accelerated.

In- / Outputs:

1. **USB port:** Input for MIDI data.

Please do not use MIDI IN socket and USB port in parallel!

2. **MIDI IN :** Input for MIDI data (DIN socket)

3. **MIDI THRU :** Output to loophrough incoming MIDI data to another MIDI device connected here.

4. **Clock :** MIDI clock signal output (original or divided rate).

5. **Reset :** Reset signal output:
MIDI-Start or Continue: low/no voltage
MIDI-Stop: high voltage.

6. **Gate :** GATE signal output; will usually be connected internally to the A-100 system bus (INT.GATE line) but may be disconnected.

7. **CV 1 :** Output for control voltage 1 (D/A converter 1); usually connected internally to the A-100 system bus (INT. CV line) but may be disconnected if desired. May be used mainly for controlling VCO pitch.

8. **CV 2 :** Output for control voltage 2 (D/A converter 2). May be used to control additional parameters just like e.g. VCF cutoff or VCA level.

Module width: 6 HP

Module depth : 30 mm

Current consumption: 200 mA

3. Setting up the A-190-4

Please note if you are using more than one A-190-4:

The A-190-4 is usually connected to INT.CV und INT.GATE on the system bus of the A-100 system.

If you want to run **more than one A-190-4** with just a single system bus, **only one** of the A-190-4's must be connected to the system bus.

Disconnect the other A-190-4 modules from the system bus by disconnecting the **two** jumpers labelled **JP2** (CV bus) and **JP3** (gate bus). Both jumpers are located on the backside of the A-190-4 circuit board. Please refer to page 19.

Before powering up your A-100 system, please use a MIDI- or USB cable to connect your MIDI device to the A-190-4:

- Connect the A-190-4's MIDI IN socket to the MIDI OUT socket of your MIDI device (master keyboard, MIDI synth, MIDI sequencer, etc.).

Or: Connect the A-190-4's USB port to your computer or MIDI device. Your MIDI software / MIDI device should automatically recognise the A-190-4.

- Now power up your System A-100. The A-190-4's display will show its operation software version number for about one second (e.g. 101).

- Patch the outputs of your A-190-4 to corresponding modules on the System A-100:

The **gate output** (6) and **CV1 output** (7) are connected to the system bus of the A-100 by default, so don't use patch cables to connect them, unless you have disconnected the jumpers JP2/JP3 (page 18) or you want to connect a third party module which does not access the A-190's system bus (please refer to the note for using more than one A-190-4). VCOs on the same system bus automatically receive CV1, and ADSRs automatically receive the gate signal.

Output	Connection examples
8 CV 2	Any module's CV input (e.g. a VCF's CV input, for controlling the filter cutoff).
4 Clock	E.g. the A-160's trigger input for MIDI-synced sequences.
5 Reset	The A-160's reset input, for MIDI control of start and stop messages; The A-140's gate or retrigger input for MIDI-triggered envelopes.

4. Operating the A-190-4

4.1. Basic Operation

When powered up, the A-190-4 idles for about one second and is ready for operation (yes, it's a busy bee). This means that incoming MIDI data is converted to analogue CVs, gate and clock signals, according to the A-190-4's settings. The display shows at first the current operating software version number, e.g. "101". The gate LED (7) will light up. The A-190-4 is now ready to receive and convert MIDI data. The Reset LED (6) and the Clock-LED (5) will light up on current MIDI activities.



Your A-190-4 features many useful options to convert MIDI data into analogue signals. In order to allow most easy and intuitive access to all available functions, you will find a simple and flat menu structure that covers all functions and parameters. Please refer to the complete menu overview on the next two pages. Navigation within this menu structure always works by using the same scheme and the four buttons:

- Hit ">|+" and "</>" buttons to move back and forth on the current menu level. By doing so, you will find six different menus plus the operation software number in the upper menu level. Once you have reached the last menu on the current level, you have to step back by hitting "</>" repeatedly. We did not implement "round robin" menus.
- When you reached the menu you would like to work on, please hit the "↵" button. Now you enter the parameter level of the desired menu.
- Hit ">|+" and "</>" buttons again to move back and forth in order to access all available parameters. Depending on the selected menu, you will find up to nine different parameters by doing so. Again, we did not implement "round robin" menus, so please use the "</>" button to move backwards at the end of a parameter selection.
- Hit "↵" again to enable the A-190-4 for receiving parameter value changes.
- Hit ">|+" and "</>" buttons again to alter the values of the selected parameter. Some values are displayed in numbers, others in abbreviations. When pressed down continuously for approx. three seconds or longer, the value change will be accelerated.

- Hit the "↵" button to leave the value level and the return to the parameter level. Hit "↵" once more to return to the menu level (highest level).

Please note:

- Parameter changes will always affect the currently outputted CV / gate / clock signal immediately. You are able to hear the changes.
- If you wish to keep your settings after powering down your A-100 system, you have to save your settings into the A-190-4's non volatile memory. This is done with the store function covered later in this manual.

4.2. Menu and Parameter Overview

On the following two pages you will find an overview of all available menus and their corresponding parameters:

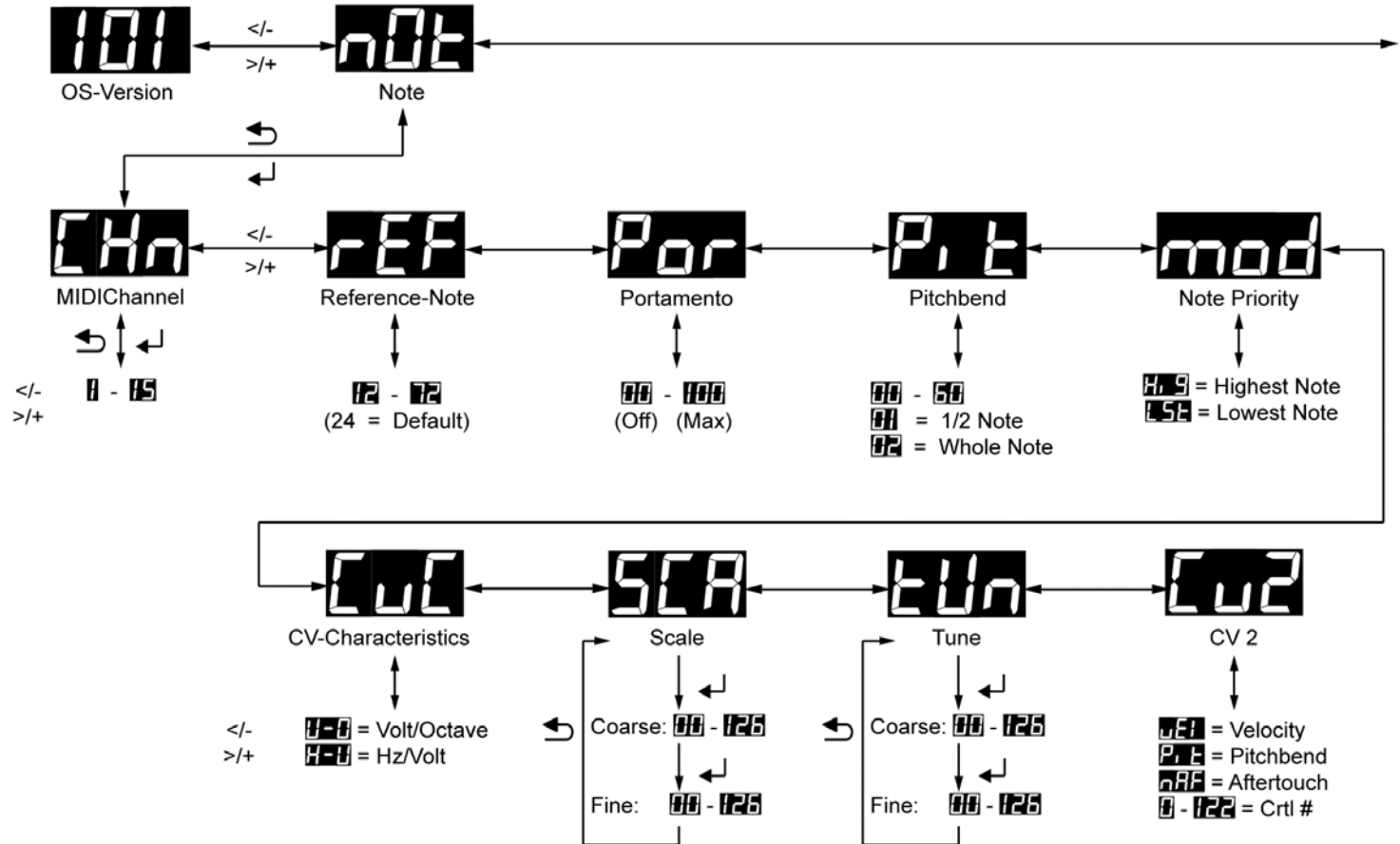

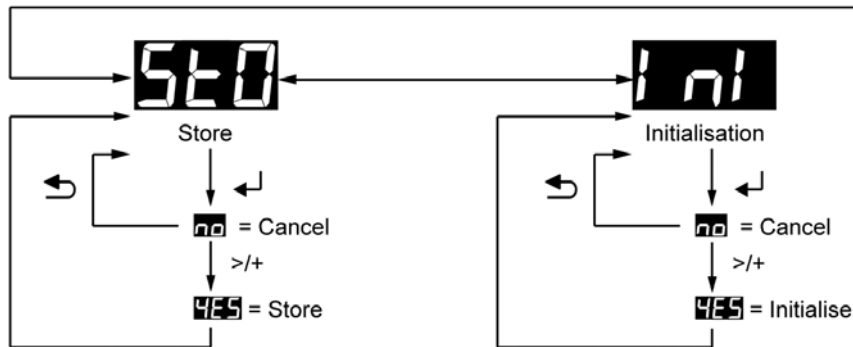
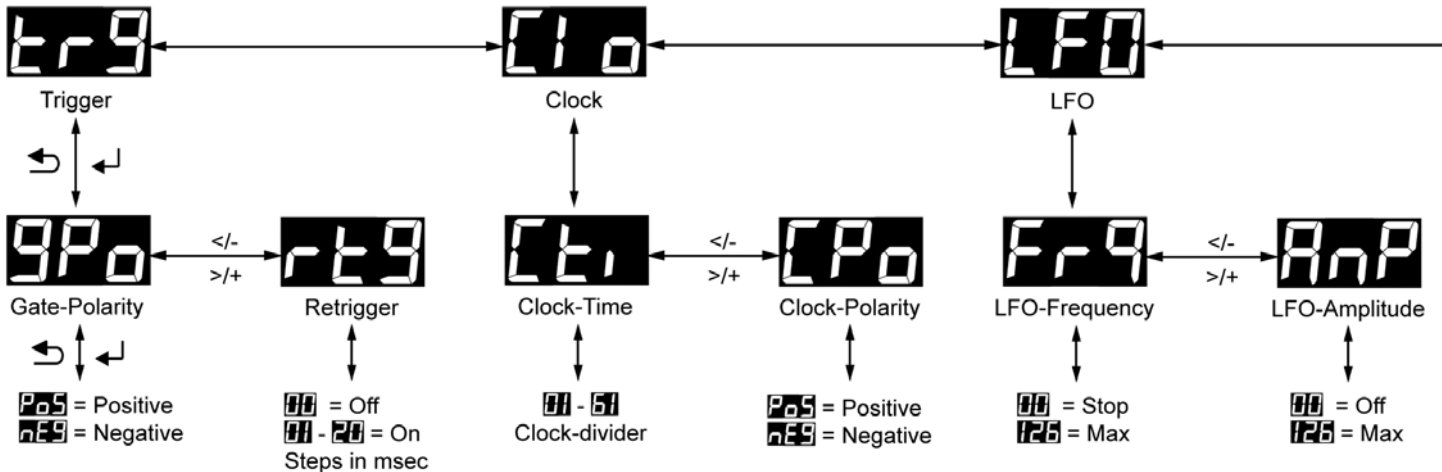

4.3 Menues and Parameters

On the following pages you will find a detailed description of all the A-190-4 menus and their parameters according to the overview on pages 8 and 9.

4.3.1 Note Menu not

The note menu covers all parameters that are used to determine the properties of both generated CVs. Once opened up by hitting "←", you will find **nine** parameters to be accessed via ">/+" and "</-" buttons.

MIDI CHANNEL CHN

Selects the desired MIDI Channel, on which your A-190-4 will receive MIDI data.

Channel # 1 to #15 are available – not channel #16. The default channel is #1.

REFERENCE NOTE ref

The reference note determines the note that corresponds to the CV1 value, adjusted with the Tune parameter.

*The value range is 12 – 72.
The default value is "C2" resp. MIDI note number 24.*

PORTAMENTO por

The portamento parameter controls the **duration** of the **portamento** in the A-190-4's built-in glide / portamento function.

*The value range is from 000 (Off) to 100 (Max).
The default value is 000.*

PITCH BEND pit

This parameter sets the **pitch bend range**. For example, if you set the range to a semitone (parameter value 01), the pitch bender of your MIDI instrument will alter the A-100's VCO pitch by a maximum interval of a semi-tone up or down.

*The value range is from 00 (Off) to 60 (Max).
A value of 01 bends the pitch by +/- a semitone.
A value of 12 bends the pitch by +/- one octave (default value).*

MODE (NOTE ASSIGNMENT) Mod

The **MODE** parameter controls the **note assignment**. It determines which note will be generated when more than one key is held down at once.

Hig *(Highest note – default setting)*

Lst *(Last note)*

CV CHARACTERISTICS CvC

This parameter sets the **voltage control characteristics** of the pitch CV output (CV1) from the A-190-4, so that it is possible to drive both common types of analog synth – vintage Korgs, Yamahas, etc., which have a linear response (Hz / V), and Rolands, ARPs, Moogs, etc. which have a logarithmic response (1V / octave).

For use with the A-100, only the V / octave setting is needed. The Hz / V option is provided for connecting external (vintage) synths which use that standard. Thus the default setting is Volt / Octave.

H-U *(Hertz / Volt)*

U-O *(Volt / Octave – default setting)*

SCALE SCA

This parameter sets the **fine scaling of the pitch-control DAC (CV1)** so that MIDI and A-100 VCO notes are exactly in tune over the whole note range.

After setting the **REFERENCE NOTE** (see above) and **TUNE** (next following parameter), please send a MIDI note to the A-190-4 – usually the note exactly one octave or several octaves above the reference note. By using the SCALE parameter, adjust the A-190-4's output voltage in order to provide perfectly tuned octave ranges.

This function is divided into a **coarse** and **fine** adjustment. Both values range from 000 to 126.

The first hit on the " ← " button accesses the coarse setting. A second hit accesses the fine setting. Hitting " ↵ " leaves the value entry menu.

For use with the A-100, please leave this value at the standard factory setting of exactly 1.00V / octave.

TUNE tUn

This parameter sets the **voltage offset** for the reference note - and works the same way as the VCO's Tune control. In normal use, this parameter is set to 0V. Thus the default value is also "0".

This function is divided into a **coarse** and **fine** adjustment. Both values range from 000 to 126.

The first hit on the " ← " button accesses the coarse setting. A second hit accesses the fine setting. Hitting " ↵ " leaves the value entry menu.

This parameter is adjusted at the factory to 0 Volts and should not be altered by the user.

CV 2 Cv2

This parameter determines the **MIDI controller data** that generates the CV sent out on the **CV2 output socket**. The voltage output range is from 0 to +10V.

The following options are available:

vEL (Velocity – default setting)

Pit (Pitchbend)

nAF (monophonic Aftertouch)

..... (MIDI controller #)

Alternatively, you may choose **any other available MIDI controller** in order to control CV2. The display lists all of them when scrolling with the " </ " and " >/+ " buttons through the available MIDI controller numbers.

Not listed controllers are not available.

4.3.2 Trigger Menue trig

The trigger menue covers all functions that are used to generate a **trigger** resp. **gate signal** from incoming MIDI data. Once opened up by hitting " ← ", you will find **two** parameters to be accessed via " >/+ " and " </- " buttons.

GATE POLARITY gPo

This parameter sets the **polarity of the gate voltage**.

PoS (positive – default setting)

nEg (negative)

For use with the A-100, this parameter should always be set to positive. The negative setting may be useful to control certain vintage synthesizers.

RETRIGGER rtg

This parameter enables you to choose between **single** and **multiple** triggering of the ADSR. With RETRIGGER on, every time a key is pressed, **a new gate signal is sent**, even if (i.e. when playing legato) another key is still held down at the same time.

*The value range is from 0 (Off) to 20 (Max).
Values change in steps of 1 millisecond.
The default setting is 0 (Off).*

GATE LEVEL (Hardware Modification)

Some vintage synthesizers require a gate level of 10V or more. In case you want to control such an instrument with the A-190-4 you may alter the gate level from +5V (default) to +12V. You can do this by changing a jumper position on the backside of the A-190-4 module. Please refer to page 19, chapter 5. "Jumper settings".

4.3.3 Clock Menu Clo

The clock menu covers all functions that are used to generate a **clock signal** from incoming MIDI data. Once opened up by hitting " ← ", you will find **two** parameters to be accessed via ">/+" and "</-" buttons. The clock signal is sent out at the clock output socket.

CLOCK TIME Cti

This parameter sets the A-190-4's internal **clock divider**. It divides the incoming **MIDI clock rate** into a certain multiple resp. longer note lengths, before sending it to the clock output (See 'note length' in the table below).

MIDI Clock pulses are 1/96th notes. By setting the divisor (amount by which the clock is divided), you can choose different note lengths:

The parameter value range is from 1 (no division) to 61 (Max). This means, there are 60 different clock divider settings available. The musically most important settings are listed in the table below. The default divisor-setting is "1" which means "no clock division".

divisor	clocks per note	note length
1	96	1/96
3	32	1/32
6	16	1/16
12	8	1/8
24	4	1/4

You may also use the A-160 clock divider module to generate different clock divisions.

CLOCK POLARITY CPo

This Parameter sets the **polarity of the clock signal** at the clock output socket.

PoS (*positive – default setting*)

nEg (*negative*)

For use with the A-100, select "positive". The negative setting is provided for connection to third party / vintage drummachines, sequencers, synths that use a negative polarity.

4.3.4 LFO Menue lfo

The LFO menu covers all functions that are used to configure the internal LFO. With the A-190-4, you're getting an extra software generated LFO which can supplement the 'real' LFOs (A-145, A-146) in your A-100 system.

LFO FREQUENCY Frq

The LFO frequency parameter controls the frequency resp. the "**speed**" of the A-190-4's **built-in LFO**.

The value range is from 000 (Off) to 126 (Max).

Please use your ears to dial in the desired frequency. With a parameter **value of 0**, the LFO is **switched off**.

LFO AMPLITUDE AnP

The LFO amplitude parameter controls the amplitude resp. the **modulation depth** of the A-190-4's internal LFO.

The value range is from 000 (Off) to 126 (Max).

4.3.5 STORE Function Sto

Save your settings permanently with the Store function: The A-190-4 is equipped with a **non-volatile memory** (EEPROM - electrically erasable programmable read-only memory) which will save your setup when powering down the A-100 system. As soon as you power up the system again, the A-190-4 will recall immediately its saved settings.

If you change the settings of various parameters, the A-190-4 stores these changes only **temporarily**, and they will be lost when you switch off the A-100 system. To save any changes in the set-up permanently, you have to **save** the set-up by using the simple to use Store function:

This is how to save the settings of the A-190-4:

As soon as your settings are complete and you wish to save them, please navigate to the Store function with the ">/+" and "</-" buttons.

- Hit " </- ". The display shows no The ">/+" button flashes.
- Hit " </- " again or " >/+ " to **cancel** the Store function.
- Hit ">/+" to **save** the current settings **permanently**.

To confirm the store function, the display shows YES for a short moment.

*If desired, you may set back the A-190-4 to it's **factory/default settings** anytime (please see 4.3.6. Initialise function).*

4.3.6 INITIALISE Function InI

You may want to erase all your parameter settings and reset the values back to their defaults. If so, please use the Initialise function.

Please navigate to the Initialise function with the ">/+" and "</-" buttons.

- Hit "↶". The display shows no The ">/+" button flashes.
- Hit "↶" again or "↷" to **cancel** the Initialise function.
- Hit ">/+" to **initialise** all parameter settings to the values shown in the following chart.
To confirm the store function, the display shows YES for a short moment.

The following chart shows the initial parameter values:

Parameter	Value	Notes
CHANNEL	1	MIDI channel #1
REF. NOTE	24	#24 / Note C2
CLOCK TIME	1	clock frequency at clock output = MIDI clock frequency
CLOCK POLARITY	PoS	positive
RETRIGGER	0	legato - ie. no retrigger
LFO FREQ.	006	
LFO AMPL.	0	LFO off
PORTAMENTO	0	no portamento
BEND WIDTH	12	1 semitone
ASSIGN CV2	vEl	velocity
ASSIGN MODE	Hig	highest note
GATE POLARITY	PoS	positive
RTRIG. TIME	0	off
CV CHAR.	U-O	1 V / octave

4.4 Using MIDI Controllers

You already learned how to assign Velocity, Pitchbend or Monophonic Aftertouch to CV2. Next to this, the A-190-4 processes some more MIDI controller in order to "remote control" the corresponding functions this way. The following MIDI controllers are processed by the A-190-4:

CONTROLLER #01 (Modulation)

This controller affects **LFO amplitude** (please refer to Note menu / LFO functions). When using this controller, parameter changes are only temporary. If you want to save the new setting permanently, please use the Store function (see page 15).

Value range: 0 to 127 LFO amplitude

CONTROLLER #05 (Portamento Time)

This controller affects **portamento time** (please refer to Note menu / Portamento function). When using this controller, parameter changes are only temporary. If you want to save the new setting permanently, please use the Store function (see page 15).

Value range: 0 to 127 Portamento time

CONTROLLER #64 (Sustain)

This controller switches **sustain** on and off.

*Value range: 0 to 63 Sustain Off
64 to 127 Sustain On*

CONTROLLER #65 (Portamento On/Off)

This controller switches **portamento** on and off.

*Value range: 0 to 63 Portamento Off
64 to 127 Portamento On*

CONTROLLER #68 (Legato)

The **retrigger function** (please refer to Trigger menu / Retrigger function) can be enabled / disabled by this controller. When using this controller, parameter changes are only temporary. If you want to save the new setting permanently, please use the Store function (see page 15).

*Value range: 0 to 63 Retrigger Off
64 to 127 Retrigger On*

CONTROLLER #92 (Tremolo)

This controller affects the **LFO frequency** (please refer to LFO menu / frequency parameter). When using this controller, parameter changes are only temporary. If you want to save the new setting permanently, please use the Store function (see page 15).

Value range: 0 to 127 *LFO frequency*

CONTROLLER #121 (All Controllers Off)

If this MIDI controller with any value is sent to the A-190-4, the **LFO amplitude** will be set to 0 (although the LFO keeps running at the same frequency) and **portamento** is switched off.

Value range: 1 to 127 (any value)

CONTROLLER #123 (All Notes Off)

If this MIDI controller with any value is sent to the A-190-4, the **gate** is turned off, and **all notes in the A-190-4's memory** are cleared. Control voltages remain at the level at which they were set at last. This function is useful to clear "hanging notes".

Value range: 1 to 127 (any value)

Controller	Effect	Setting
Cont # 01 n	Modulation	n = LFO voltage amount sent to CV1
Cont # 05 n	Glide Time	Portam. Time = n x 20 ms
Cont # 64 n	Sustain	n = 0 to 63 : Off n > 63 : On
Cont # 65 n	Glide	n = 0 to 63 : Off n > 63 : On
Cont # 68 n	Retrigger	n = 0 to 63 : Off n > 63 : On
Cont # 92 n	LFO Freq.	n = LFO frequency (CV 1)
Cont # 121 n	All Cont. Off	n can be any number. LFO modulation amount = 0, Glide off
Cont # 123 n	All Notes Off	n can be any number. All notes off, GATE = off

List of recognised MIDI controllers
(they cannot be linked to CV2)

5. Jumper Settings

You may customise your A-190-4 to your needs by removing / changing positions of some jumpers on the backside of the module's circuit board. You will find a total of seven jumpers, but only three of them are of importance.

JP2 (CV-bus) and JP3 (gate bus):

If you want to run **more than one A-190-4** with just a single system bus, **only one** of the A-190-4's must be connected to the system bus.

Disconnect the other A-190-4 modules from the system bus by disconnecting the **two** jumpers labelled **JP2** (CV bus) and **JP3** (gate bus). Both jumpers are located on the backside of the A-190-4 circuit board. Please refer to page 5.

JP4 (gate level):

Some vintage synthesizers require a gate level of 10V or more. In case you want to control such an instrument with the A-190-4 you may alter the gate level from +5V (default) to +12V. You can do this by changing the jumper JP4's position on the backside of the A-190-4 module. The lower position provides +5V, the upper position +12V. Please refer to page 12, 13 chapter 4.3.2 "Trigger menu".

**Please leave all other Jumpers untouched !!!
Otherwise serious malfunction will occur.**

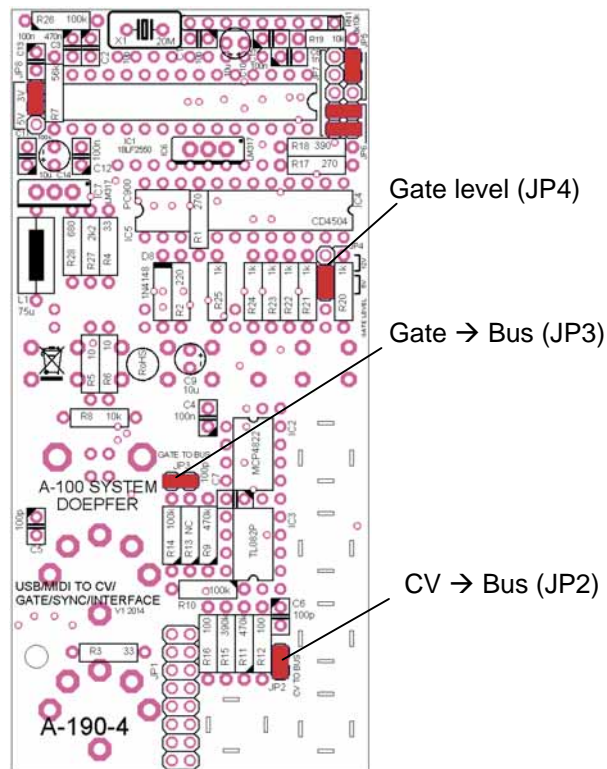

6. Application Examples

6.1. Simple synthesizer standard patch with one envelope generator

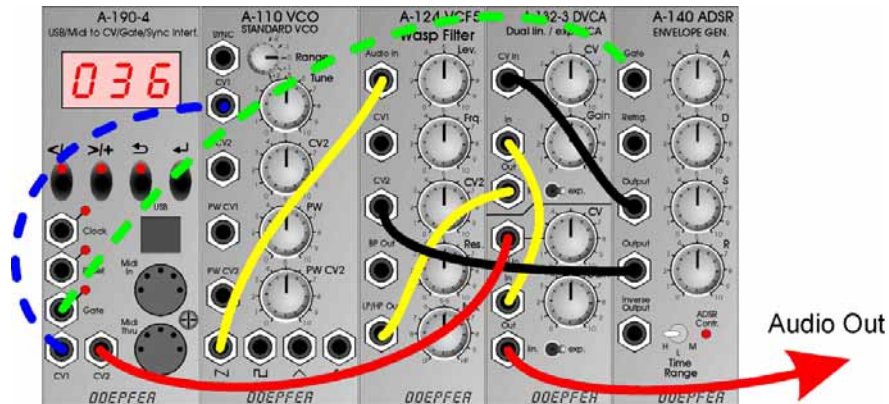

This is a simple synthesizer patch with one VCO A-110 that is processed by a VCF (A-124 Wasp filter in this example, but any other filter may be used) and two VCAs (Dual VCA A-132-3). The first VCA is controlled by the envelope of the ADSR A-140. The second VCA is controlled by CV2 of the A-190-4 and used for a Midi controlled overall loudness. The VCF frequency is controlled by both the A-140 envelope (width adjustable level). The dashed blue connections (CV1 A-190-4 → CV1 In A-110 and Gate A-190-4 → Gate In A-140) are not required if the bus jumpers of the modules A-110, A-140 and A-190-4 are installed.

6.2. Application of A-190-4 and Precision Adder A-185-2

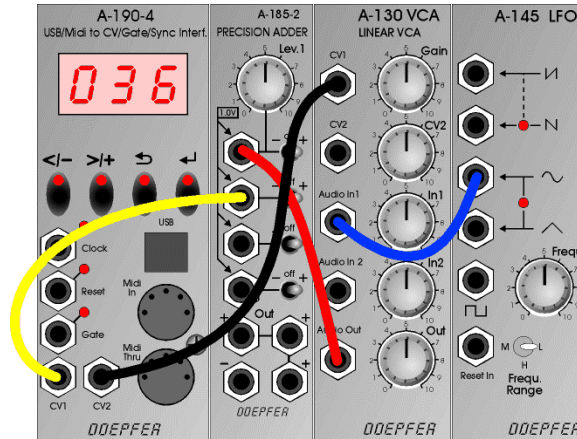

In this application the A-185-2 is used to add up several voltages that are used to control the pitch of all VCOs that are connected to the same bus board as the A-185-2:

- CV1 is connected to one of the inputs of the A-185-2 without attenuator
- CV2 is connected to the input of the A-185-2 to be able to adjust the pitch bend width. The output of the VCA is connected to one of the inputs of the A-185-2 without attenuator. That way the Midi controller (e.g. modulation = control change #1 resp the setting mod) is used for the modulation depth. If the A-145 is replaced by a VCLFO A-147 the CV2 of the A-190-4 may be used to control even the modulation frequency of the LFO.
- The CV output of a sequencer A-155 can be connected to the remaining free input of the A-185-2. Then CV1 of the A-190-4 is used to transpose the sequence of the A-155 via Midi.

Attention: In this application the bus CV jumper of the A-190-4 has to be removed and the bus CV jumper of the A-185-2 has to be installed ! Otherwise a short circuit between both CV outputs will occur !

All rights reserved © 2014 Doepfer Musikelektronik GmbH Vers. 1.2/2014-05-14

